

PU Sports Mini Balls (48 Units) (2.3kg)
Code : ITSP - 011/ WM 240/ EM 265



PU Smiley Colours Balls (24 Units)
Code : ITSP - 012/ WM 280/ EM 310 (2.2kg)



Massage Balls (40 Units) (2.1kg)
Code : ITSP - 020/ WM 192/ EM 210



Jumping Balls (5 Units) (3.3kg)
Code : ITSP - 022/ WM 230/ EM 250



Basketball (1pc) (0.5kg)
Code : ITSP - 043/ WM 42/ EM 46

Saiz Bola
No.5



Bola Keranjang

Volleyball (1pc) (0.4kg)
Code : ITSP - 044/ WM 49/ EM 53

Saiz Bola
No.5



Bola Tampar

Jello Basketball (1 Unit) (0.5kg)
Code : ITSP - 148/ WM 59/ EM 65



Size : 7

Jello Sports Football (1 Unit) (0.5kg)
Code : ITSP - 149/ WM 80/ EM 88



Size : 5

Jello Football (1 Unit) (0.5kg)
Code : ITSP - 146/ WM 52/ EM 57



Size : 5

Jello Volleyball (1 Unit) (0.4kg)
Code : ITSP - 147/ WM 55/ EM 60



Size : 5

Rubber Ball No: 4 (1pc) (0.4kg)
Code : ITSP - 080/ WM 32/ EM 36



Size: 4 (Random color)

Rubber Ball No: 5 (1pc) (0.6kg)
Code : ITSP - 194/ WM 35/ EM 39



Size: 5 (Random color)

Set Bola Belon (1.2kg)

Code : ITSP - 105/ WM 150/ EM 165

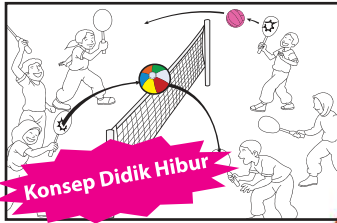

Konsep Didik Hibur



- 12 biji bola belon
- 1 Jaring penyimpanan bola
- 1set Pam Bola Belon



Balls Net Carry Bag (Set of 4) (0.9kg)

Code : ITSP - 025/ WM 156/ EM 170

Can carry 17 balls (approx) in one net.



Example only / Without ball
85 cm

NETS ONLY

Foldable Ball Rack (12kg)

Code : ITR - 002/ WM 940/ EM 1030

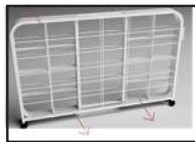

PVC Ball Rack (1 Unit) (5.6kg)

Code : ITR - 006/ WM 490/ EM 520



Take sports ball from here.



Wheel x 4

Efficiently store balls for quick and easy access with these PVC ball racks

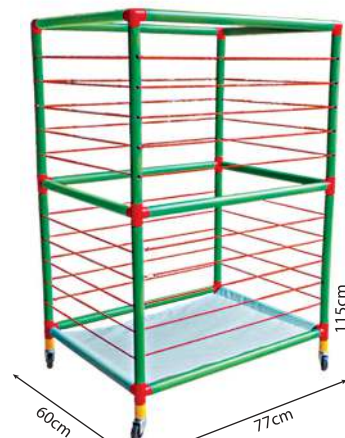

Features:
· Light & easy to move

These lightweight, durable, PVC Ball Racks are perfect for exercise ball storage. Keep your exercise balls secure and organized with the Ball Rack. They are easy to move and the green colour PVC goes with any decor.



Sample

Pétanque Set (6 Ball) (4.7kg)

Code : ITSP - 135/ WM 148/ EM 163

Set includes:

6 balls, 1 measuring string, 1 wooden ball (target)



Weight each ball: 720g

Pétanque Set (3 Ball) (2.3kg)

Code : ITSP - 136/ WM 92/ EM 102

Set includes:

6 balls, 1 measuring string, 1 wooden ball (target)



Weight each ball: 720g

Tennis Balls (12pcs) (1.1kg)

Code : ITSP - 186/ WM 84/ EM 90



Twin Balls (0.1kg)

Code : ITSP - 108/ WM 40/ EM 44



Basketball Set (1 Unit) (7.5kg)
Code : IXT - 072C/ WM 520/ EM 570



Plastic Pool Balls (100pcs) (0.6kg)
Code : IXT - 070B/ WM 140/ EM 154



Flip & Catch (Set of 4) (1.7kg)
Code : ITSP - 110/ WM 396/ EM 430

Set mengandungi:

- 1 pundi kacang
- 1 bola foam
- 1 papan flip

Saiz pundi kacang:

9cm x 9cm

Saiz bola:

9cm diameter

Saiz papan:

60cm x 8cm



EVA Bowling Set (S) (0.7kg)

Code : ITSP - 033/WM 190/ EM 205

Set bowling EVA ini direka khas untuk kanak-kanak, memberikan pengalaman bermain yang selamat dan menyeronokkan.

Diperbuat daripada bahan ringan dan lembut, ia sesuai untuk digunakan di dalam rumah atau di luar. Set ini termasuk 10 pin, 1 bola, dan alas permainan, serta didatangkan dengan beg penyimpanan yang praktikal.

Pin: 2.4"(L) X 7.2"(T)

Bola: 4"

Alas Bola: 18" x 15.5"

Lebih sesuai untuk kanak-kanak berumur 7 tahun dan kebawah.



ITS Stand Pump (0.5kg)

Code : ITSP - 049/WM 60/ EM 65



ITS Hand Pump (0.2kg)

Code : ITSP - 050/WM 22/ EM 24



ITS Foot Pump (0.7kg)

Code : ITSP - 051/ WM 90/ EM 99

Maximum pressure 120psi



Jarum Pam Bola ITS (10pcs) (0.1kg)

Code : ITSP - 052/ WM 12/ EM 13



Multipurpose Electric Pump (4.2kg)

Code : ITSP - 138/ WM 700/ EM 750

**Light-weight
&
Compact Design**

Product Description :

- Inflating For Car, Bus, Motorbike, Sport, Ball, Camping Equipment, Van, car.
- Max Voltage: AC220v
- Max Amperage: 3 A
- Duration: 12-15 Min
- Max Pressure: 10kg/cm2 (150PSI)
- Displacement: 70 L/Min



Digital Stopwatch (0.2kg)
Code : ITSP - 003/ WM 49/ EM 54



Stopwatch (PC 2000A) (0.1kg)
Code : ITSP - 157/ WM 39/ EM 43



Professional Stopwatch (50 Memory)
Code : ITSP - 158/ WM 150/ EM 165 (0.2kg)



Stopwatch
Code : ITSS - 007/ WM 155/ EM 170



Scoreboard Multi-Function Turning Points (1.1kg)

Code : ITSP - 160/WM 125/ EM 135



Substitution Board (1 Unit) (2.3kg)

Code : ITSP - 161/WM 350/ EM 385

Saiz: 84cm x 38cm



Wisel Besi ITS (1pc) (0.1kg)

Code : ITSP - 053/WM 8/ EM 9



Whistle (1pc) (0.1kg)

Code : ITSP - 042/WM 12/ EM 13



Professional Chess Clock (0.5kg)

Code : ITSP - 159/ WM 395/ EM 430



Heart Rate Monitor Watch

Code : ITSS - 009/ WM 366/ EM 390

Supports 100+ sports and activity modes, suitable for various exercises such as running, walking, cycling, and fitness training.



Basketball Planner (0.6kg)

Code : ITSP - 163/ WM 90/ EM 99



Magnetic Board



Soccer Planner (0.6kg)

Code : ITSP - 162/ WM 90/ EM 99



Magnetic Board



Sport Day Flags With Plastic Sticks

Code : ITSP - 102/ WM 375/ EM 410 (2.3kg)

Color: Red/Orange/Yellow/Blue/Green

Flag Size: 151cm x 92cm/ Stick Size: 153cm height



Sport Day Flag (BLUE)

Code : ITSP - Flag B/ WM 49/ EM 54 (0.5kg)



(Flag ONLY)

Sport Day Flag (RED)

Code : ITSP - Flag R/ WM 49/ EM 54 (0.5kg)

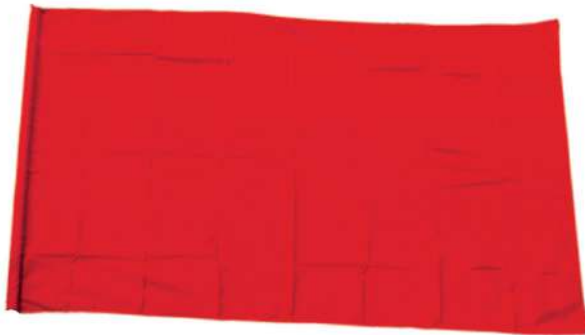

(Flag ONLY)

Sport Day Flag (YELLOW)

Code : ITSP - Flag Y/ WM 49/ EM 54 (0.5kg)



(Flag ONLY)

Sport Day Flag (GREEN)

Code : ITSP - Flag G/ WM 49/ EM 54 (0.5kg)

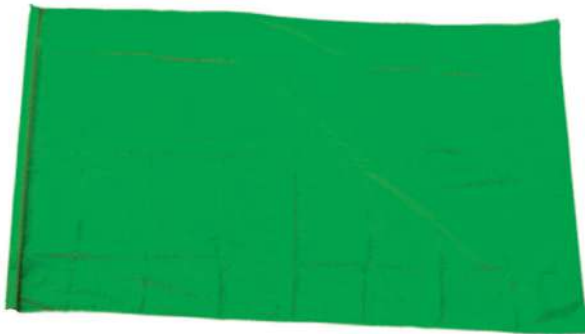

(Flag ONLY)

Sport Day Flag (ORANGE)

Code : ITSP - Flag O/ WM 49/ EM 54 (0.5kg)



(Flag ONLY)

Bendera Kejohanan Balapan Dan Padang (1pcs) (0.15kg)
Code : ITSP - 124/ WM 120/ EM 130



Flag Size : 3' x 6'
Stick Size : ø2.5cm x 153cm

Bendera Segitiga (8kg)
Code : BN - 13/ WM 100/ EM 110



Digantung dalam aktiviti sukan



Sport Day Cap (Set of 40) (3.4kg)
Code : ITSP - 005/ WM 260/ EM 290

Description: Keep the sun out of their eyes
Colour : Blue, Green, Red, Yellow

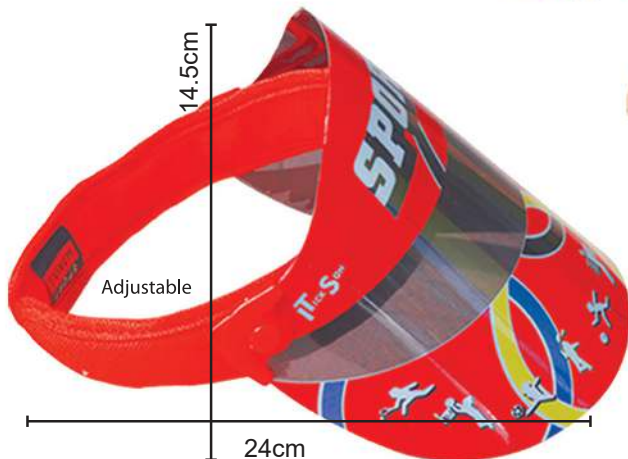

Pundi Kacang Segi Empat Tepat (2.1kg)

Code : ITSP - 084/ WM 165/ EM 180 (40pcs)

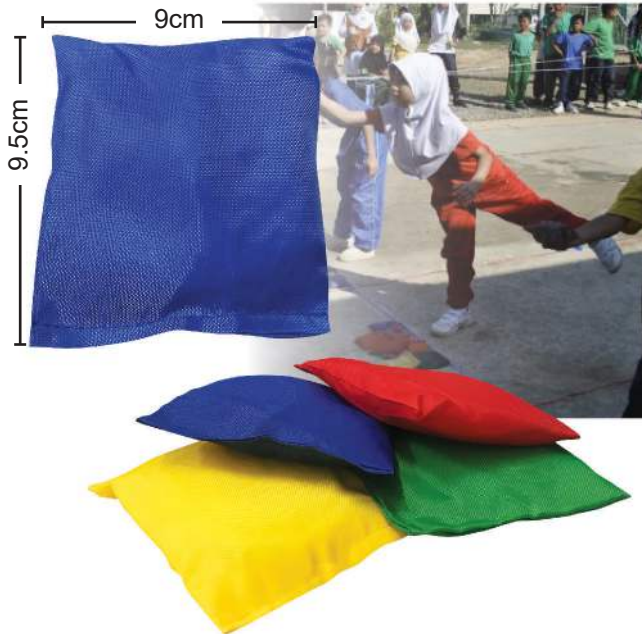

Number Bean Bag (10pcs) (1.2kg)

Code : ITSP - 177/ WM 95/ EM 105



Material : Nylon
Weight : 1.2kg
Size : 12(W) x 11cm (H)
Colour : Red, Yellow, Orange, Blue And Green

Lane Marker Cones (Set of 8) (7.8kg)

Code : ITSP - 181/ WM 490/ EM 520

- Set includes number 1 to 8.
- Number are on each sides.
- Number are colored red/black.
- Easy storage.
- **Material:** Plastic



Sports Training Bibs (Primary School) (1pc) (0.1kg)

Code : ITSP - 174/WM 25/ EM 27

Purpose : Sports Training, Football, Soccer, Basketball, Netball & Team Building Activity



RED



Green



Yellow



Orange



Blue



Purple



Sports Training Bibs (Secondary School) (1pc) (0.2kg)

Code : ITSP - 175/WM 25/ EM 27



RED



Yellow



Blue



Green



Purple



Orange



Purpose : Sports Training, Football, Soccer, Basketball, Netball & Team Building Activity



PENDIDIKAN JASMANI DAN KESIHATAN

Sack Race Jumping Bags (4pcs) (0.8kg)

Code : ITSP - 173/ WM 260/ EM 285

Pendidikan Jasmani

HIGH QUALITY

Kemahiran Motor Kasar

GROUP OF SPORT

Item specifics
Material: High quality waterproof fabric
Color: Red, Blue, Yellow, Green

Handles

86cm

Ø60cm

Starting Block (5.5kg)

Code : ITSP - 182/ WM 330/ EM 360

Material: Aluminum (safety, durability)
Light and durable pressed aluminium profiles,
ergonomic shape of high comfortable
foot supports.

- Customize degree angle to fit your torso
and hip height to get maximum push off

PENDIDIKAN JASMANI

KONSEP KECEGERASAN DAN KESIHATAN

Press

Adjustable

HIGH QUALITY

Starting Blocks suitable for schools competitions and training.

7.5cm

64cm

12cm

17cm

14cm

23cm

Referee Flag (2pcs) (0.2kg) Code : ITSP - 184/ WM 50/ EM 55

Material: Plastic, Nylon, Sponge Handle



- Pair of two checkered referee flags
- Waterproof
- Swivel handle for smooth flag movement
- Foam hand grips making them easy to hold
- Protective bag included



GREAT FOR SCHOOLS SPORTS GAMES AND GENERAL FUN!

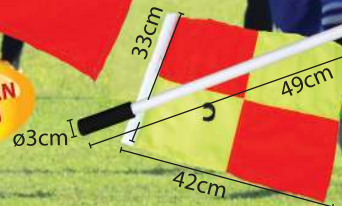

Signal Flag (4 pcs) (0.3kg) Code : ITSP - 180/ WM 100/ EM 110

GREAT FOR SCHOOLS SPORTS GAMES AND GENERAL FUN!
READY-STEADY-GO & STOP FLAGS



Material : Plastic rod / Nylon / Sponge handle
Colour : Red / Yellow / White / Green
Weight : 0.3kg (4 unit)



Sponge Relay Baton (Set of 20) (1.2kg)

Code : ITSP - 183/ WM 140/ EM 155

Item Type: Relay baton
 Material : Stainless steel + sponge
 Size : \varnothing 3cm x 30.5 cm
 Weight : 1.2 (0.06 = 1pc)
 Color : Red / Blue / Yellow / Orange / Green



Features:

- Non-slip Sponge steel
- Very light, easy to carry.
- Suitable for track and field running and track relay.

PENDIDIKAN JASMANI

KONSEP KECERGASAN DAN KESIHATAN

AKTIVITI FIZIKAL

GREAT FOR SCHOOLS SPORTS GAMES AND GENERAL FUN!

Three-Legged Race Bands (Set of 20) (1kg)

Code : ITSP - 193/ WM 179/ EM 199

- Set includes 20pcs bands.
- 4 colors, each 5 pieces.
- Strong velcro with soft backside.
- Stretchable elastic.

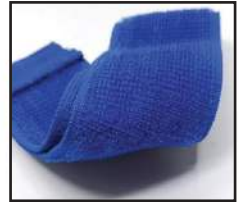

5cm



50cm



PENDIDIKAN JASMANI DAN KESIHATAN

Papan Tanda Rumah Sukan (0.8kg)

Code : ITKK - 036/ WM 180/ EM 198 (1pcs) (BM or BC)



ITKK - 036 - 12 (BC)



ITKK - 036 - 12 (BM)



ITKK - 036 - 15 (BC)



ITKK - 036 - 15 (BM)



ITKK - 036 - 13 (BC)



ITKK - 036 - 13 (BM)



ITKK - 036 - 16 (BC)



ITKK - 036 - 16 (BM)



ITKK - 036 - 14 (BC)



ITKK - 036 - 14 (BM)



ITKK - 036 - 18 (BC)



ITKK - 036 - 18 (BM)

KAMI JUGA MENERIMA
TEMPAHAN KHAS /
SPECIAL ORDER
WM 200/ EM 220

欢迎订购其它
款式的设计
WM 200/ EM 220

Dimensi : 26cm x 61cm x (93cm - 112cm)

PAPAN TANDA RUMAH SUKAN 协会及运动会标志牌

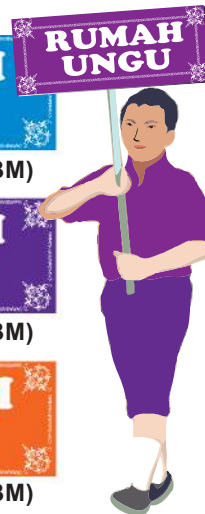

Papan Tanda Persatuan (1pcs) (BM / BC) (0.8kg)

Code : ITKK - 036/ WM 180/ EM 198

Papan Tanda ini diperbuat daripada besi berkualiti dan tahan karat. Didatangkan dengan pemegang dari bahan besi krom yang boleh dilaraskan mengikut kesesuaian ketinggian. Sesuai digunakan untuk perbarisan hari sukan, hari kebangsaan dan sebagainya. Menerima lain-lain tambahan mengikut permintaan.

Dimensi : 26cm x 61cm x (93cm - 112cm)



ITKK - 036 - 1(BM)



ITKK - 036 - 4(BM)



ITKK - 036 - 7(BM)



ITKK - 036 - 10(BM)



ITKK - 036 - 2(BM)



ITKK - 036 - 5(BM)



ITKK - 036 - 8(BM)



ITKK - 036 - 11(BM)



ITKK - 036 - 3(BM)



ITKK - 036 - 6(BM)



ITKK - 036 - 9(BM)

Tempahan Khas
juga diterima
RM: WM 200/ EM 220



Terompah Gergasi (3 Peserta) (2kg)
Code : ITSP - 178/ WM 150/ EM 165



Terompah Gergasi (2 Peserta) (1.5kg)
Code : ITSP - 179/ WM 130/ EM 143

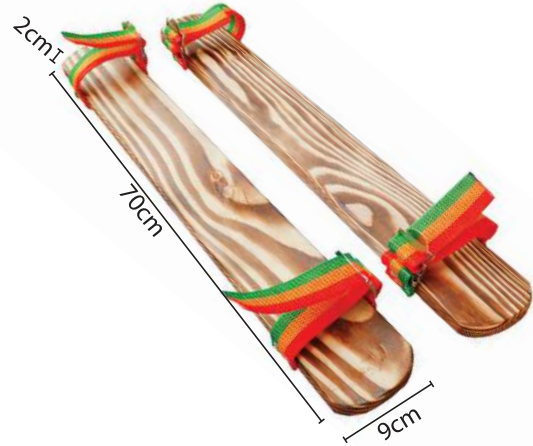

Sukan Tarik Tali (Tug Of War) (8.2kg)
Code : ITSP - 139/ WM 460/ EM 500



Sukan Tarik Tali (Tug Of War) (14.2kg)
Code : ITSP - 140/ WM 550/ EM 590



Sukan alatan "Tarik Tali" untuk sekolah kebangsaan

Mini Rainbow Penguin Games (4pcs + 1 air stick) (1.5kg)

Code : ITSP - 187/ WM 900/ EM 990



Permainan memukul Penguin dengan air stik, dimainkan oleh 5 orang iaitu seorang penyerang dan 4 penguin. Penyerang hendaklah memukul penguin dengan air stik, pada masa itu, penguin hendaklah secepat mungkin duduk mencangkung untuk elak pukulan air stik. Permainan ini bertujuan untuk meningkatkan tahap kecerdasan kanak-kanak serta dapat meningkatkan daya tumpuan dan perhatian.

Huge Rainbow Penguin Games (4pcs + 1 air stick) (2kg)

Code : ITSP - 188/ WM 1100/ EM 1210

Material : Nylon
 Bahan : Berkualiti dan tahan lasak
 - Sesuai untuk hari sukan
 - Senaman dalaman / luaran



i-Sport Games Set Biru (3.2kg) Code : ITK - 062/ WM 385/ EM 415 (1 Set)



i-Sport Games Set Kuning (3.2kg) Code : ITK - 063/ WM 385/ EM 415 (1 Set)



i-Sport Games Set Hijau (3.2kg) Code : ITK - 064/ WM 385/ EM 415 (1 Set)



i-Sport Games Set Merah (3.2kg) Code : ITK - 065/ WM 385/ EM 415 (1 Set)



i-Kon (0.6kg)

Code : ITK - 066/ WM 59/ EM 65 (1pc)



Pendidikan Jasmani Dan Pendidikan
Kesehatan Tahun 1,2,3,4,5,6
体育与健康教育 1,2,3,4,5,6 年级

i-Klip (0.1kg)

Code : ITK - 067/ WM 12/ EM 13 (1pc)



i-Stick 153# (0.3kg)

Code : ITK - 068/ WM 29/ EM 32 (1pc)

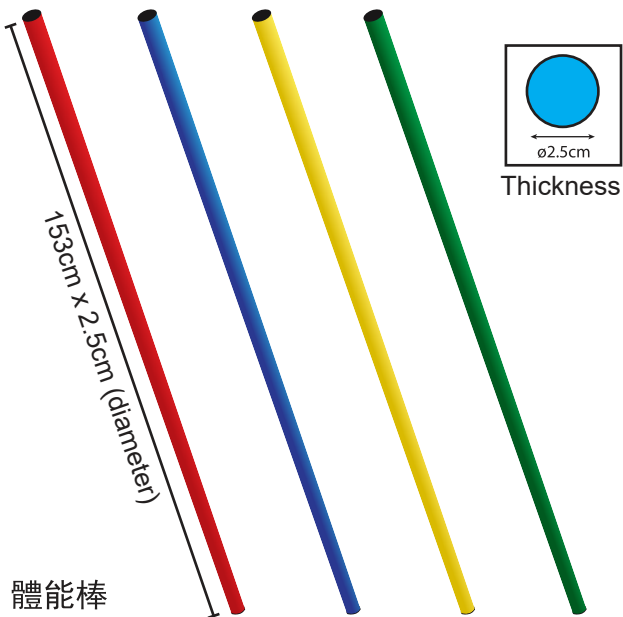

i-Stick 100# (0.2kg)

Code : ITK - 069/ WM 23/ EM 25 (1pc)

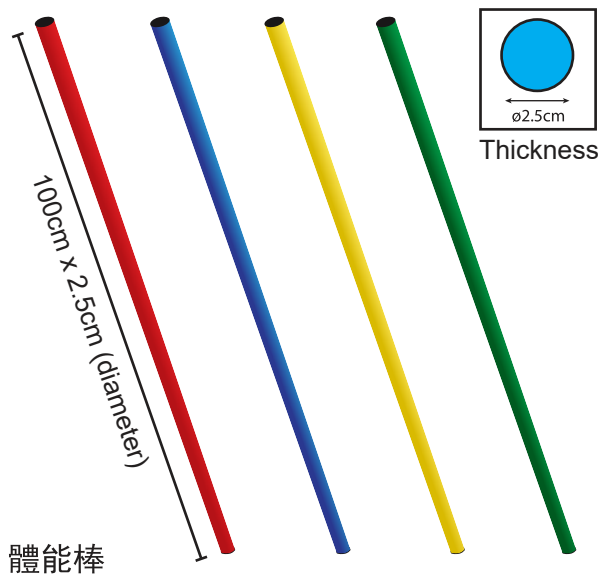

i-Field Maker (Set A) (1.9kg)

i- 系列体能运动场标记

3.3 inch

Code : ITSP - 057/ WM 190/ EM 210

(Set of 50)



Disertakan dengan beg jaring bertali jerut dan rak supaya peralatan mudah disimpan serta tidak berselerak



i-Field Maker (Set B) (1.7kg)

i- 系列体能运动场标记

2 inch

Code : ITSP - 058/ WM 165/ EM 180

(Set of 50)

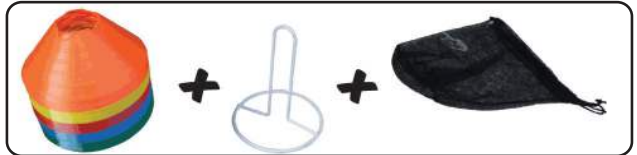
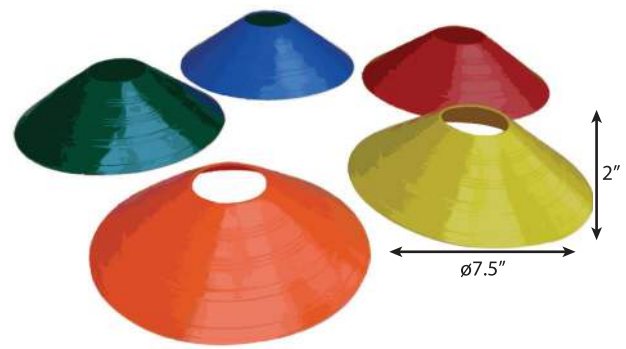

i-9 Inch Flexible Colour Cone (2kg)

i-9 寸系列柔软站柱 (Set of 48)

Code : ITSP - 056/ WM 180/ EM 198

Size : 9" x 5.5" x 5.5"



i-Gelung Latihan Sukan (1.3kg)

i- 系列运动体能环 (Set of 12)

Code : ITSP - 060/ WM 130/ EM 140

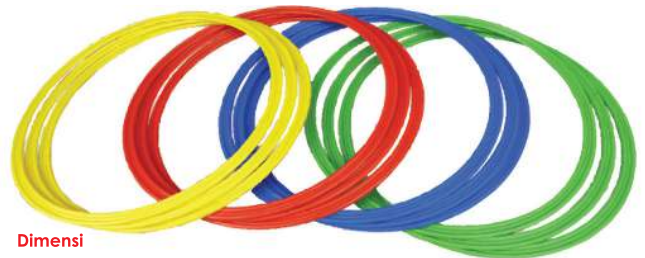

Dimensi

16inci Ø

Meningkatkan kemahiran motor kasar dan kebolehan mengawal keseimbangan badan. Boleh diubahsuai menjadi perbagai jenis permainan. Digunakan untuk Pendidikan Jasmani dan kepelbagaian aktiviti.



Throwing Ring With i-Kon (4kg)

Code : ITSP - 121/WM 320/ EM 350



Throwing Games (Plastic Ring) (1.9kg)

Code : ITSP - 122/WM 195/ EM 215 (60 pcs)



Speed Agility Ladder (Set of 4) (3.8kg)

Code : ITSP - 185/WM 185/ EM 205

Item Type : Ladder For Training
Material : Plastic
Size : Section 6m/12 Rungs
Color : Red, Yellow, Green, Blue

Adjustable up to 15-inch for different levels.



- Improves coordination, balance, and body awareness.
- Great for any age user, from children to older adults.
- Ideal for athletic training to improve foot speed and reactivity.
- Lightweight, roll-up design is compact and travel-friendly.
- Adjustable rung sizes.



i-Sport Training Hurdles (Set of 12) (4 Colour)

i-系列体育训练跨栏器材 (2.9kg)

Code : ITSP - 061/WM 310/EM 340

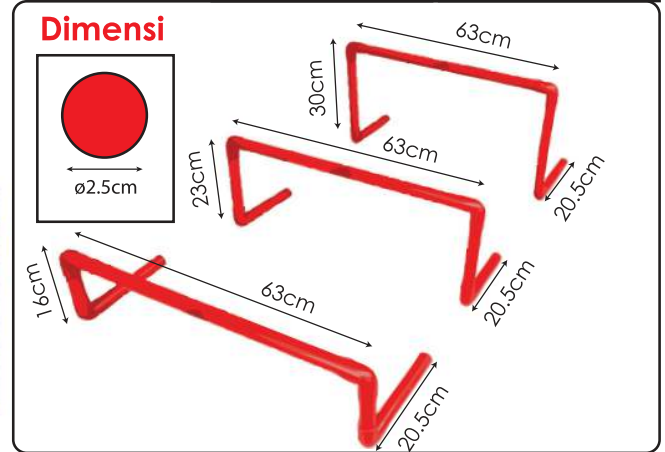
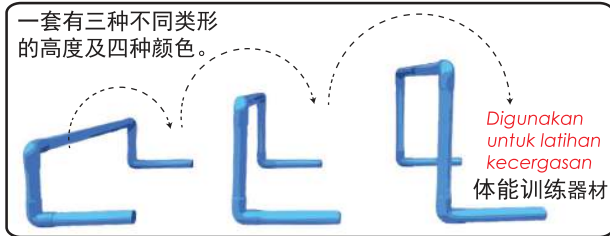
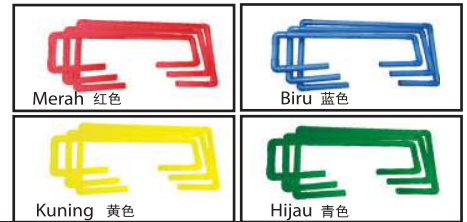

Training Mini Hurdles (Set of 4) (1.7kg)

Code : ITSP - 137/WM 240/EM 260



Exciting

Group Activity

Creative Play

High Quality

EASY INSTALLATION

Clip

Can be Rotated 360°

Easy to keep

Adjustable and Foldable

- 3-in-1 Step Training Mini Hurdles
- Adjustable height on each hurdle
- Suitable for different age ranges
- Warm up for sports
- Indoor / Outdoor
- Safe and Easy
- 4 colour :

Gimnastik Trampoline 36" (6kg)
Code : ITSP - 062/ WM 360/ EM 390



Size: 36 inch

Gimnastik Trampoline 40" (8kg)
Code : ITSP - 063/ WM 420/ EM 460



Size: 40 inch

Gimnastik Trampoline 48" (11kg)
Code : ITSP - 064/ WM 480/ EM 520



Size: 48 inch

Gimnastik Trampoline 60" (14kg)
Code : ITSP - 065/ WM 720/ EM 790



Size: 60 inch

Adjustable Multipurpose Cone (3kg) Code : ITSP - 004/ WM 288/ EM 310 (Set of 4)

This adjustable multipurpose cone is provided to be noticed easily, to be carried conveniently by having a small volume. The top can be equipped with special warning light.

Features & Benefits:

- ✓ Ideal in case of car breakdowns
- ✓ Mark barriers and hazardous areas
- ✓ Visible from all directions for up to 1000 metres
- ✓ 3M reflective tape is standard on all Pro Series Porta Cones
- ✓ Ease of handling and storage
- ✓ fits into car boot or under seat
- ✓ Very stable and lightweight due to low centre of gravity
- ✓ Integrated waterproof/ splashproof flashing LED light for night or twilight conditions

Uses & Applications:

- ✓ Private Use
- ✓ Traffic
- ✓ Police
- ✓ Fire Service
- ✓ Sports
- ✓ School



SOFT TRAINING SHOT PUT (Medicine Ball)

Berkualiti



Code : ITSP - 128 (1pc)
WM 40/ EM 44

- Bahan dari getah.
- Pasir di dalam bola.
- Jika dijatuhkan tidak memantul.
- Berat dan keliling bola : 1kg, keliling Ø10cm

1kg



Code : ITSP - 129 (1pc)
WM 45/ EM 49

- Bahan dari getah.
- Pasir di dalam bola.
- Jika dijatuhkan tidak memantul.
- Berat dan keliling bola : 2kg, keliling Ø10cm

2kg



Code : ITSP - 130 (1pc)
WM 65/ EM 71

- Bahan dari getah.
- Pasir di dalam bola.
- Jika dijatuhkan tidak memantul.
- Berat dan keliling bola : 3kg, keliling Ø17cm

3kg



Code : ITSP - 131 (1pc)
WM 75/ EM 82

- Bahan dari getah.
- Pasir di dalam bola.
- Jika dijatuhkan tidak memantul.
- Berat dan keliling bola : 4kg, keliling Ø18cm

4kg



Code : ITSP - 132 (1pc)
WM 85/ EM 93

- Bahan dari getah.
- Pasir di dalam bola.
- Jika dijatuhkan tidak memantul.
- Berat dan keliling bola : 5kg, keliling Ø19cm

5kg

"Medicine ball" memiliki fungsi yang lebih luas dan digunakan sebagai media latihan praktikal untuk meningkatkan kekuatan otot dan kecergasan badan.

"Medicine ball" memiliki berat yang berbeza dan sesuai digunakan untuk tingkatan latihan. Untuk permulaan biasanya menggunakan beban yang ringan terlebih dahulu dan menambah beban secara bertahap jika tubuh dapat beradaptasi dengan beban sebelumnya.

Aktiviti Fizikal

Perancangan program

Berikut ini beberapa tip dalam program dan menjalankan sesi latihan menggunakan "Medicine Ball":

Selalu pastikan Anda melakukan pemanasan dan pendinginan.

Mulai sesi latihan dengan jenis latihan ringan, kemudian lanjutkan ke latihan berat.



Kemahiran Motor Kasar

Anda akan memerlukan 4 jenis bola berbeza untuk latihan. Untuk permulaan, Anda harus menggunakan bola ringan dan secara bertahap ke bola berat. Berlatihlah di ruangan yang cukup luas. Gunakan bola secara disiplin.

Tahun 3 (m/s 33)



Mengikut Silibus Pendidikan Jasmani Dan Pendidikan Kesihatan Tahun 2,4,5,6, 该产品被列为教科书, 二、三、四、五、六年级体育与健康教育。

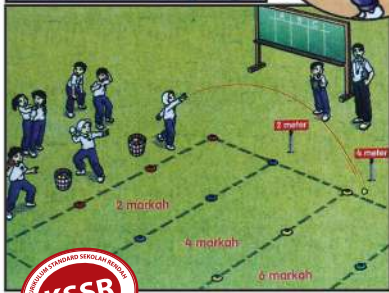

Tahun 5 (m/s 42)



Tahun 4 (m/s 43)

SPORT GAMES ACTIVITY SET



Sport day Activity

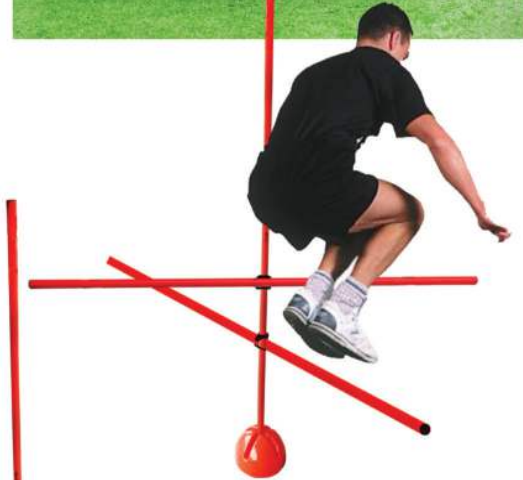

Soccer Training

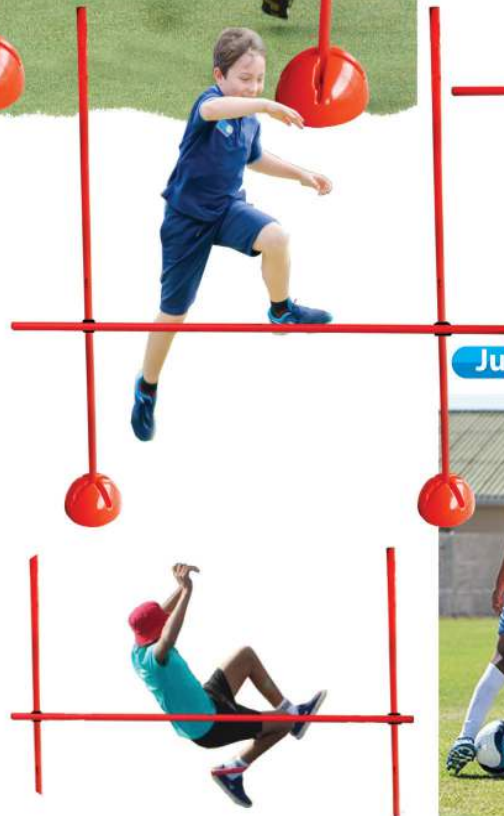

Jumping activity



SPORT GAMES ACTIVITY SET (2.7kg)

Code : ITSP - 169-R / WM 290/ EM 319 (1 set)

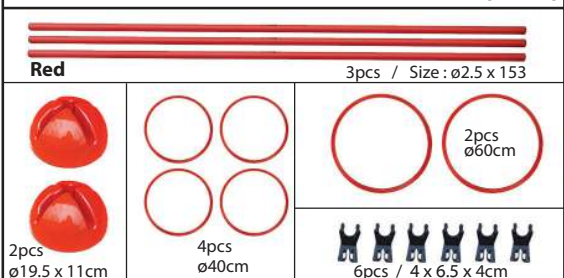

Code : ITSP - 169-B / WM 290/ EM 319 (1 set)

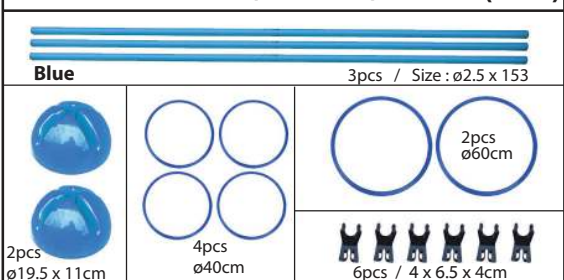

Code : ITSP - 169-Y / WM 290/ EM 319 (1 set)

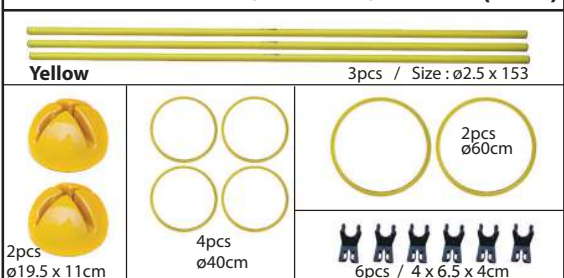

Code : ITSP - 169-G / WM 290/ EM 319 (1 set)

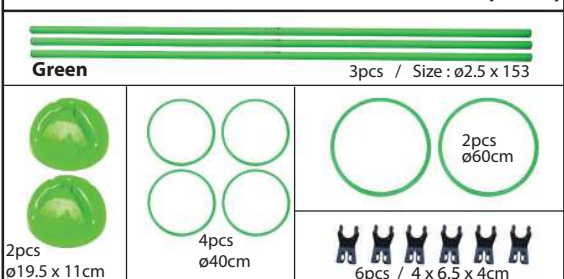

SOCCER TRAINING SET (2.7kg)

Code : ITSP - 170-R / WM 220/ EM 240 (1 set)

<p>Red</p> <p>Ø19.5 x 11cm</p> <p>4pcs</p>	<p>40cm</p> <p>4pcs</p>	<p>60cm</p> <p>4pcs</p>
--	-------------------------	-------------------------

Code : ITSP - 170-B / WM 220/ EM 240 (1 set)

<p>Blue</p> <p>Ø19.5 x 11cm</p> <p>4pcs</p>	<p>40cm</p> <p>4pcs</p>	<p>60cm</p> <p>4pcs</p>
---	-------------------------	-------------------------

Code : ITSP - 170-Y / WM 220/ EM 240 (1 set)

<p>Yellow</p> <p>Ø19.5 x 11cm</p> <p>4pcs</p>	<p>40cm</p> <p>4pcs</p>	<p>60cm</p> <p>4pcs</p>
---	-------------------------	-------------------------

Code : ITSP - 170-G / WM 220/ EM 240 (1 set)

<p>Green</p> <p>Ø19.5 x 11cm</p> <p>4pcs</p>	<p>40cm</p> <p>4pcs</p>	<p>60cm</p> <p>4pcs</p>
--	-------------------------	-------------------------



Konsep Kecergasan Dan Kesihatan



CORNER FLAGS SET

(3.1kg)

Pendidikan Jasmani

Aktiviti Fizikal

Konsep Kecergasan Dan Kesihatan



- High quality outdoor pole Soccer Corner Flags.
- Convenient to carry and durability.
- Quality Nylon with great color fastness.
- The lightweight and close weave enable it to fly in the slightest breeze.



Add water



Code : ITSP - 171-R / WM 270/ EM 297 (1 Set)



Red Stick: 4pcs / Size : Ø2.5 x 153



Water Base : 4pcs
Ø19.5cm x 11cm



Clip : 4pcs
Size : ø3 x 3cm

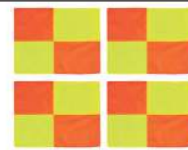

Flag : 4pcs
Size : 46 x 36cm

Code : ITSP - 171-Y / WM 270/ EM 297 (1 Set)



Yellow Stick: 4pcs / Size : Ø2.5 x 153



Water Base : 4pcs
Ø19.5cm x 11cm



Clip : 4pcs
Size : ø3 x 3cm



Flag : 4pcs
Size : 46 x 36cm

Code : ITSP - 171-B / WM 270/ EM 297 (1 Set)



Blue Stick: 4pcs / Size : Ø2.5 x 153



Water Base : 4pcs
Ø19.5cm x 11cm



Clip : 4pcs
Size : ø3 x 3cm

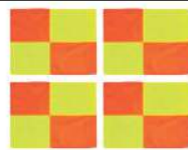

Flag : 4pcs
Size : 46 x 36cm

Code : ITSP - 171-G / WM 270/ EM 297 (1 Set)



Green Stick: 4pcs / Size : Ø2.5 x 153



Water Base : 4pcs
Ø19.5cm x 11cm



Clip : 4pcs
Size : ø3 x 3cm

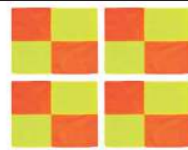

Flag : 4pcs
Size : 46 x 36cm

Softball Glove 12.5" (0.4kg)
Code : ITSP - 142/ WM 90/ EM 99



Tahun 4 (m/s 31)

Softball (0.2kg)
Code : ITSP - 125/ WM 29/ EM 32



10cm (diameter)

Wooden Softball Bat 79cm (0.8kg)
Code : ITSP - 144/ WM 75/ EM 82



Softball Glove 10.5" (0.3kg)
Code : ITSP - 141/ WM 65/ EM 70



Tahun 4 (m/s 29)

Wooden Softball Bat 66cm (0.6kg)
Code : ITSP - 145/ WM 65/ EM 71



Soft Tee Ball Set (Full Set) (0.7kg)

Code : ITSP - 101/WM 185/ EM 200

Tee Ball atau T-Ball adalah sukan yang berasaskan besbol dan bertujuan sebagai pengenalan kepada kanak-kanak mengenai kemahiran besbol dan bergembira ketika beriadah. Sesuai untuk kegunaan murid-murid sekolah rendah dan **mengikut Subjek Pendidikan Jasmani dan Pendidikan Kesihatan Tahun 2.**

EVA体能球棒系列产品被列为教科书二年级体育与健康教育里的单元三第22面“小小击球手”



Alat Permainan Tee

- 1 Bat 52+/- 2mm (diameter)
- 1 Ball 68+/- 2mm (diameter)
- 1 stand
- 1 Out Tube + 1 In Tube + 1 Tee Bar
- 1 Carton = 6 Sets

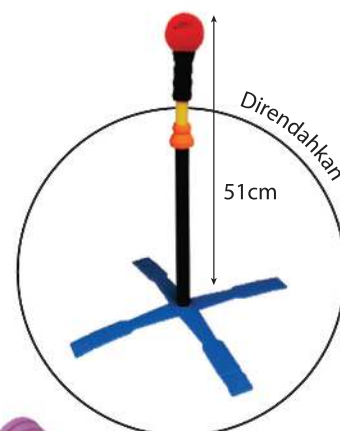

Set Peralatan

Fun way to learn the game of baseball. Adjustable height for all ages, soft foam bat and ball with plastic batting tee.



Rondas Kriket (Cricket) (0.9kg)

Code : ITSP - 114/ WM 220/ EM 240

Diperbuat daripada bahan plastik yang berkualiti dan disaluti getah busa EVA. Setiap sudut bahan tidak bersegi dan selamat untuk digunakan oleh kanak-kanak dan tidak mendatangkan kecederaan sekiranya terkena pada bahagian sudut alatan. Penggunaan bahan plastik dan getah busa EVA membuatkan peralatan lebih ringan dan selamat untuk dikendalikan oleh kanak-kanak.

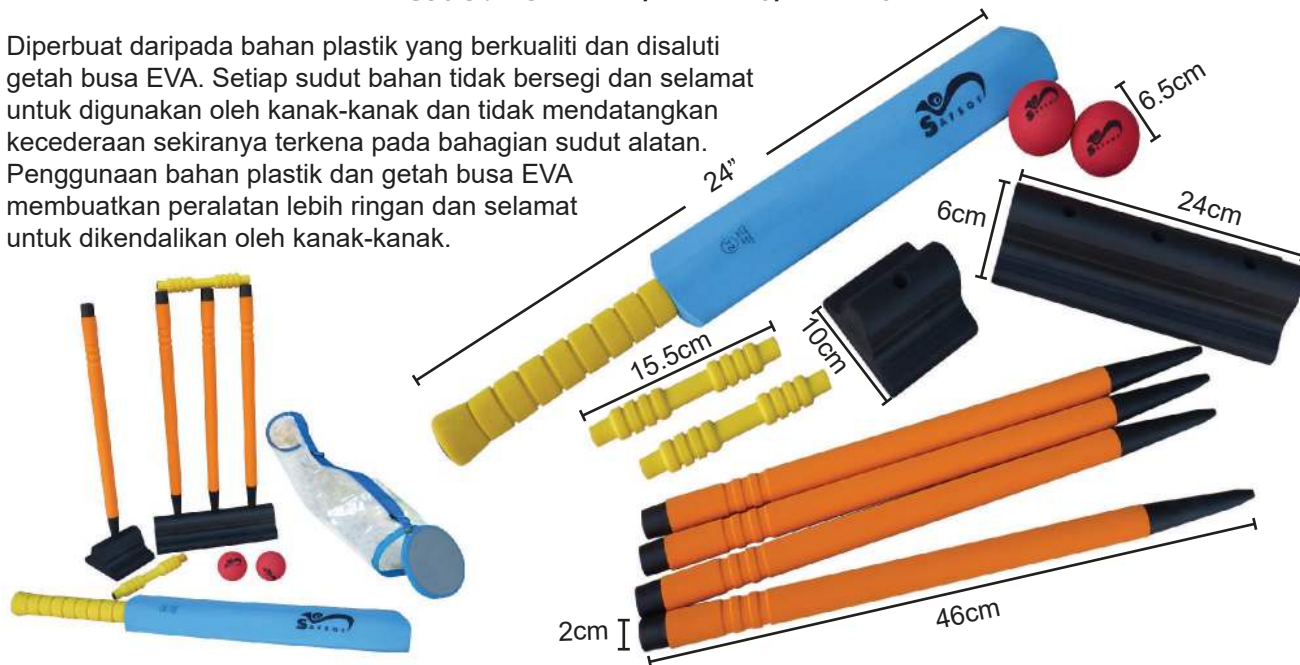

Rondas Kriket (3kg)

Code : ITSP - 167/ WM 250/ EM 275

Sample only



Kemahiran Motor Kasar

Titik Kontak berada di bahagian hujung bat dan di tengah bola.

Aktiviti Fizikal

Letak bola ke dalam gelung untuk menamatkan giliran pemukul.

Sambut bola yang dipukul untuk memamatkan pemukul.

Mengikut Silibus Pendidikan Jasmani Dan Pendidikan Kesihatan Tahun 3 Dan 4 "Rondas Kriket"

该产品被列为教科书三和四年级体育与健康教育单元三基本球类技能



Tahun 4 (m/s 28)



Tahun 4 (m/s 31)



Raket Latihan 912 (Set of 2) (0.3kg)

Code : ITSP - 036/ WM 49/ EM 54

Raket Badminton yang diperbuat daripada bahan besi berkualiti.
Mengandungi 2 batang raket di dalam beg kanvas berzip.



Shuttlecocks Greendiamond No.4

Code : ITSP - 038/ WM 62/ EM 68 (0.3kg)

Bulu tangkis berjenama
DIAMOND bersaiz no. 4.
Mengandungi 12 biji bulu tangkis di dalam setiap tabung.
Lebih Sesuai Untuk Gelanggang Tertutup



Shuttlecocks Bluediamond No.6

Code : ITSP - 039/ WM 52/ EM 58 (0.3kg)

Bulu tangkis berjenama
DIAMOND bersaiz no. 6.
Mengandungi 12 biji bulu tangkis di dalam setiap tabung.
Lontaran Lebih Tepat.



Raket Latihan 3000 (Set of 2) (0.5kg)

Code : ITSP - 037/ WM 62/ EM 68

Raket Badminton yang diperbuat daripada bahan besi berkualiti
Mengandungi 2 batang raket di dalam beg kanvas berzip.



Plastic Shuttlecocks (3pcs) (0.1kg)

Code : ITSP - 087/ WM 12/ EM 13



PENDIDIKAN JASMANI DAN KESIHATAN

ITS Ping Pong Balls (60pcs) (0.4kg)

Code : ITSP - 032/ WM 80/ EM 88



ITS Ping Pong Set (0.3kg)

Code : ITSP - 045/ WM 43/ EM 48



Advance

1 Raket ping pong dengan beg
26cm x 15.5cm

ITS Ping Pong Set (0.4kg)

Code : ITSP - 046/ WM 52/ EM 58

Beginner

2 Raket
3 biji bola
dan bag
25.5cm x
15cm



Menepati
Standard ITTF

ITS Ping Pong Set (0.4kg)

Code : ITSP - 047/ WM 56/ EM 62

Beginner

2 Raket
3 biji bola
dan bag
25.5cm x
15cm



Menepati
Standard ITTF

Exercise Mat (1kg)

Code : ITSP - 002/ WM 69/ EM 76



Features:

- Easy to clean with damp cloth
- Easy to store and carry
- Size : 68" x 24"
- Smooth
- It's light and comfortable
- Thickness 6mm

Sport Foam Cubes (20 pcs) (2.5kg)

Code : ITSP - 021/ WM 490/ EM 540

Size : (W)23 x (D)14 x (H)7cm



High Density Foam Mats (Set of 4)

Code : IXT - 052D/ WM 280/ EM 300 (2.4kg)

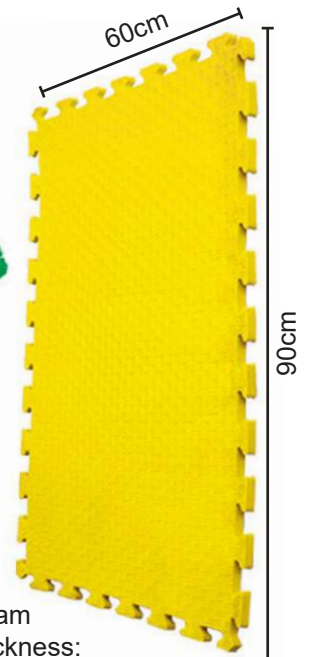
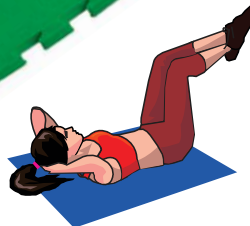

Foam thickness: 1.5cm

Multipurpose Foam Mattress (Set of 4) (6.4kg)

Code : ITSP - 009/ WM700/ EM 750



Pendidikan Jasmani Dan Pendidikan Kesehatan Tahun 1,2,3,4,5,6. Unit 7 "Tubuh Cergas Otak Cerdas" (Muka Surat 60-61)



WATERPROOF



Play & Learn

Mattress Cover : Tarpaulin (Waterproof & Easy To Clean)
High Density
Size : (W) 122 x (D)61 x (H) 10.2 cm



Taekwondo

Sleeping

Gymnastics Folding Incline Mat (7.5kg)

Code : ITSP - 118/ WM 990/ EM 1090

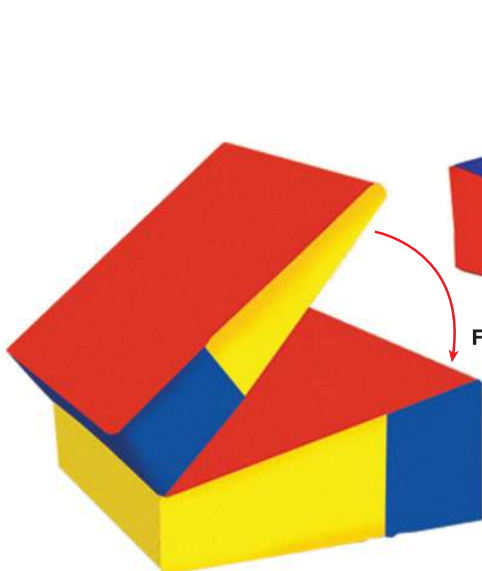

Folding

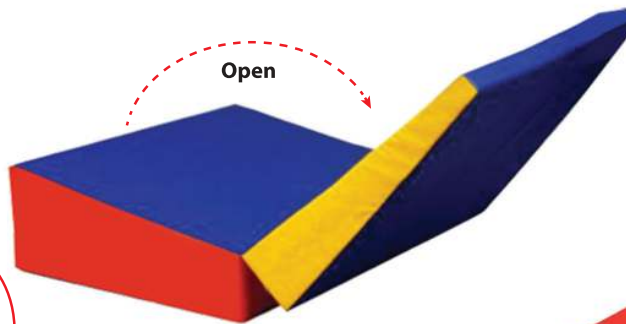

Open



SIZE : 150 x 100 x 35cm

Konsep Kecergasan Dan Kesihatan

Peti Lombol

Code : IXT - 3402/ WM 1499/ EM 1650

Pendidikan Jasmani

Kemahiran Motor Kasar

Sesuai digunakan dalam aktiviti kelas PJK, gimnastik atau acara sukaneka. Permukaan peti lombol yang lembut lebih selamat digunakan. Boleh melatih dan mempertingkatkan kemahiran pergerakan asas seperti melompat, lompat kangkang, dan sebagainya.



Aktiviti Fizikal



Bergerak perlahan menyusur di atas peti lombol dengan melemutkan anggota badan.

Menggerakkan tubuh badan untuk menunjukkan perkaitan bahagian tubuh badan dengan alatan. Pelakuan yang dilakukan dalam kemahiran ini ialah menggerakkan bahagian tubuh badan semasa dialatan.

67cm

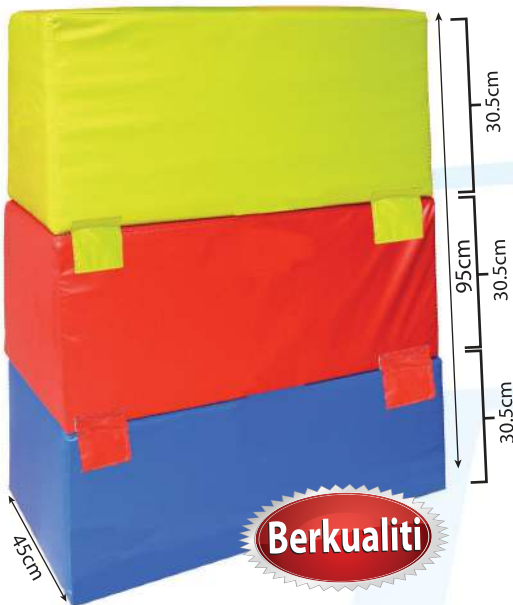

Berkualiti

- Material** : Kain PVC berkualiti
- Set** : 1 Set (3 tingkat)
- Warna** : Warna *random* mengikut stok sedia ada.

Mengikut Silibus Pendidikan Jasmani Dan Pendidikan Kesihatan Tahun 2,4.

Unit 3, Unit 1, Bertajuk Mari Melompat dan Gimnas Jaya.

该产品被列为教科书，二年级及四年级体育与健康教育，内页里的单元一和单元十一“摘水果”及“弹跳小超人”。

Gimnastik Asas Peti Lombol (12.4kg/13kg)

Code : IXT - 3404/ WM 1450/ EM 1590

Para Guru berkesan membantu murid-murid menjadi lebih cergas, tubuh sihat, disiplin,

bijak, segar, ceria, kesihatan mental dan gembira.

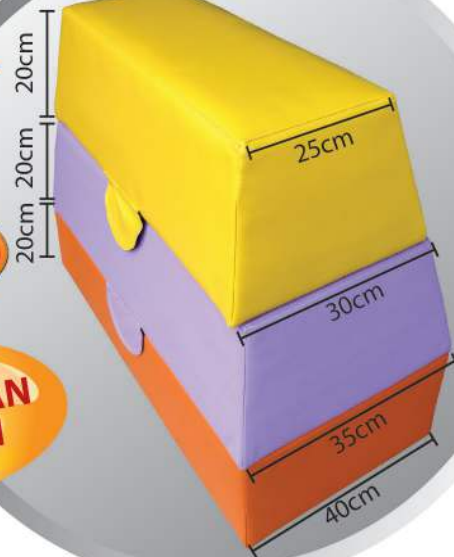

Diperbuat dari kain PVC tebal, tahan lasak, kukuh dan lembut. Span berkualiti tinggi, tahan lasak, tebal dan fleksibel. Mudah dibersihkan.



KONSEP DIDIK HIBUR

Papan Anjal (Springboard) (16.8kg)

Code : ITSP - 127/WM 795/ EM 874



Berkualiti

Pendidikan Jasmani

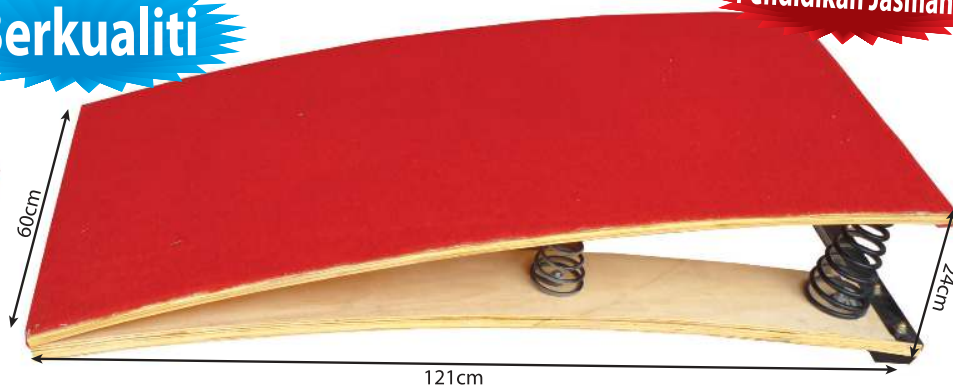

121cm

24cm

60cm

Kemahiran Motor Kasar

Direka untuk gimnastik sekolah, diperbuat daripada kayu, karpet dan spring yang berkualiti. Sesuai digunakan dalam aktiviti kelas PJ, gimnastik atau acara sukaneka. Boleh melatih dan mempertingkatkan kemahiran pergerakan asas seperti melompat, lompat kangkang, dan sebagainya. Dapat meningkatkan daya fikiran, keyakinan dan juga keberanian. Selain itu murid dapat mengembangkan perkembangan motor kasar dan juga motor halus.

Peti Lombol 5 Tingkat (20kg)

Code : IXT - 3403/WM 1200/ EM 1300

- Diperbuat dari kayu pinus.
- Terdiri dari 5 susunan dan susunan dapat dilepaskan.
- Busa lembut dibungkus dengan bahan kulit imitasi.



Boleh di lepaskan mengikut peringkat.

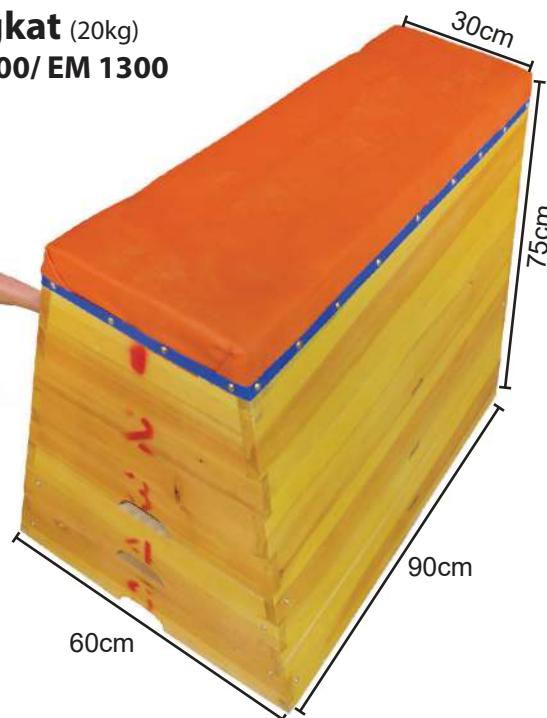

30cm

75cm

90cm

60cm

Multi-Colour Skipping Rope (3kg)

Code : ITSP - 071/ WM 240/ EM 264

(Set of 40)

Panjang tali:
90 inci



Wooden Skipping Rope (0.1kg)

Code : ITSP - 103/ WM 8/ EM 9



Saiz : 6

Panjang tali berukuran 97 inci

Hula Hoop (24") (1 Unit) (0.2kg)

Code : ITSP - 070/ WM 25/ EM 28

Random color
Subject to stock availability

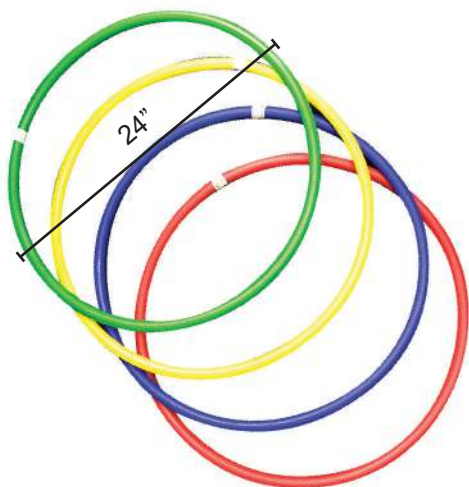

Size: 24 inch

Hula Hoop (30") (1 Unit) (0.2kg)

Code : ITSP - 073/ WM 28/ EM 31 (0.23kg)

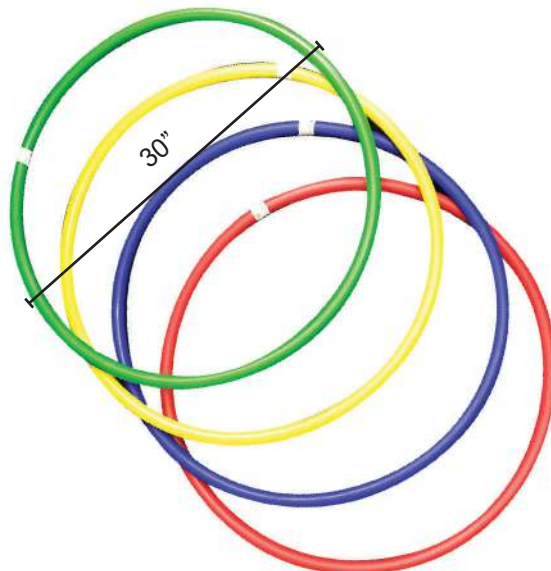

Size: 30 inch

Giant Hula Hoop (Set of 6) (4.2kg)

Code : ITSP - 115/ WM 429/ EM 465

- High quality, Soft and safe, does not hurt your skin and muscle.
- So much fun to exercise your waist and enhance all movement skills.
- It's a perfect game for all ages.
- Covered with high density soft foam, durable materials.
- Swing around, be slim and fit!



**SOLID
DURABLE
STRONG
WEIGHTED**

MULTIPLE RANDOM COLORS



SET OF
6



SIZE: 30 INCH +-

**MOTOR
SKILL
DEVELOPMENT**

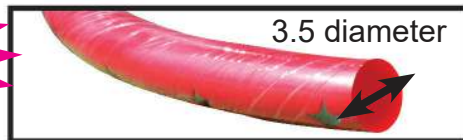

3.5 diameter



Multi Gym Eight Station (1 Unit)

Code : ITSS - 001/WM 36000/ EM 38500

- Anggaran Saiz: **4450mm x 3620mm x 2150mm**
- Kapasiti Pengguna: Sehingga 8 orang pada satu masa.
- Salutan: Kemasan cat serbuk (powder coating) tahan karat.
- Tempat Duduk: Kусyen empuk, tahan lasak dan mudah dibersihkan.

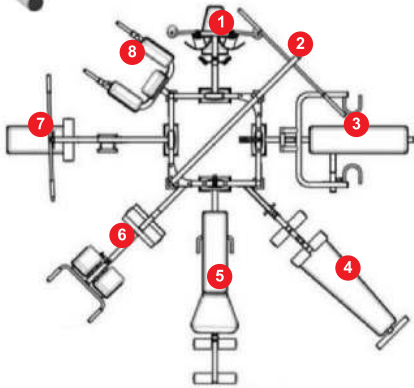
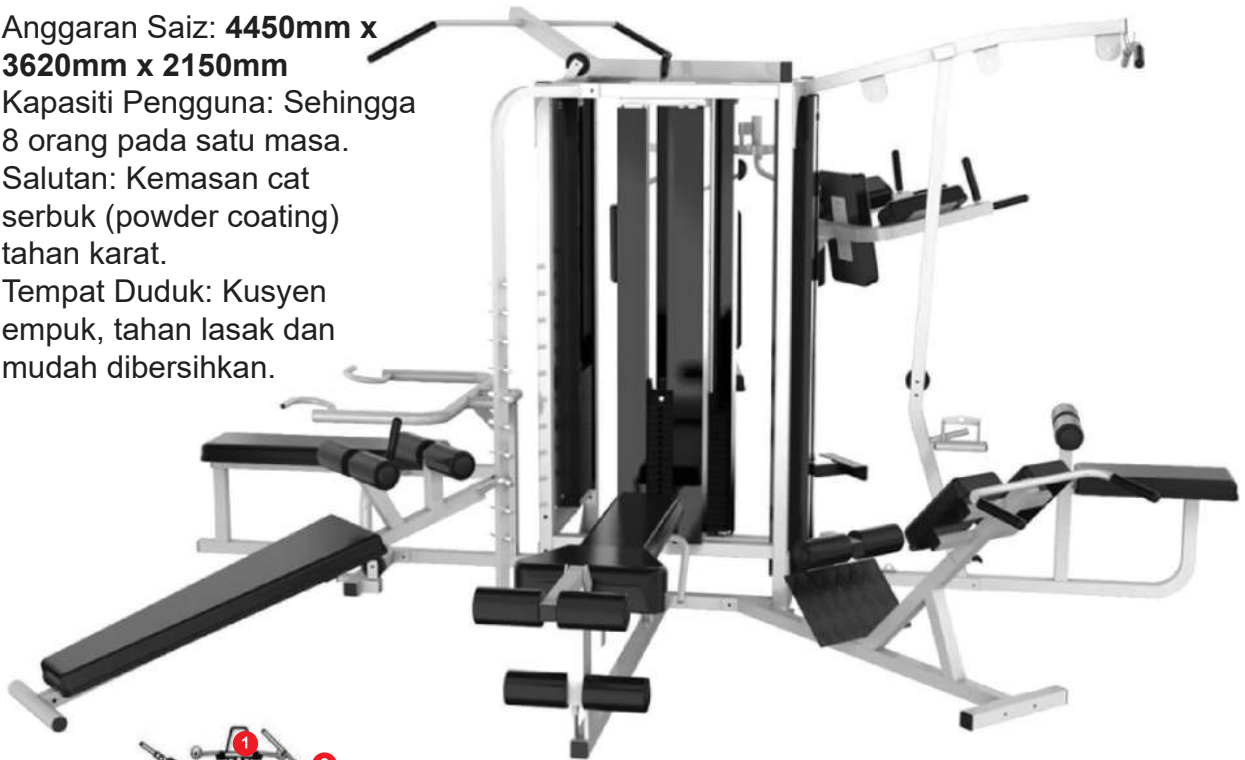

1. Pectoral Fly Station
2. Pull-up Station
3. Chest Press Station
4. Sit-up Station
5. Leg Extension / Curl Station
6. Hyper Extension Station
7. Lat Pulldown Station
8. Vertical Knee Raise Station



Treadmill (1 Unit)

Code : ITSS - 004/WM 19000/ EM 20900

- Size of Screen / Display Type - Large 21.5" Color Touchscreen.
- 6 Mode available: **Fast Mode, Live Mode, Target Mode, Training mode, Track mode, Race Running.**
- Provides one USB port and one headphone jack for the user.
- Supports online music and video streaming, and wireless internet access.
- Workout belt running area: 155 cm x 60 cm
- Motor Power: 3.0 ↔ 7.0 CHP
- Speed Range: 1 - 20 kmp/h
- Incline Range 0 to 20%



Main Screen



Fitness Bike (1 Unit)

Code : ITSS - 005 / WM 17000/ EM 18500

Main Screen



Press Rack (1 Unit)

Code : ITSS - 006/ WM 5900/ EM 6400



Sample



Speed Trap Timing System (1 Set) (2.5kg)

Code : ITSS - 010/WM 19800/ EM 20800

- Wireless timing gate system designed for sprint and athletic testing.
- Timing accuracy to one thousandth of a second (0.001).
- Wireless range approximately 230 meters.
- Handheld timer has sunlight-readable display.
- Comes with carrying case.

WIRELESS

HIGH-PRECISION



Set includes:

- Handheld Timer
- Smart Start Unit
- 2x Photogates
- 2x Tripods



Scan for User Manual



Dumbbell Rack (10 Tier) (12.4kg)

Code : ITSS - 003/WM 700/ EM 770



Sample

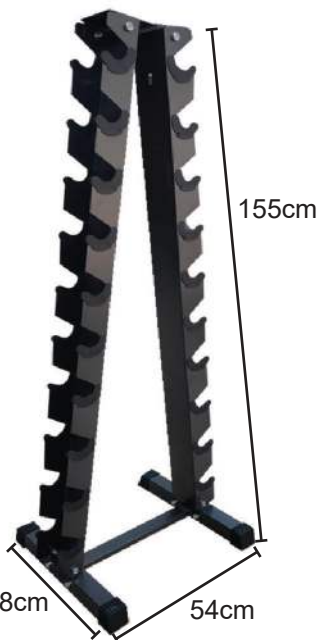

Balance Board (2kg)

Code : ITSS - 014/WM 240/ EM 250

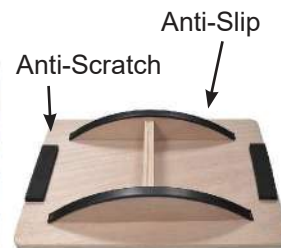

FIXED-WEIGHT DUMBBELLS (LB)

- **Material:** Vinyl/ Neoprene Coated.
- 1 set include **1 pair fixed weight dumbbells.**
- Thick, durable vinyl/neoprene coats.
- Colorful and smooth surface.
- No rust.
- Comfortable grips.



<p>Code: ITSP 192-A WM 26/ EM 29 (1pair)</p> <p>1LB</p>	<p>Code: ITSP 192-B WM 42/ EM 46 (1pair)</p> <p>2LB</p>	<p>Code: ITSP 192-C WM 62/ EM 68 (1pair)</p> <p>3LB</p>	<p>Code: ITSP 192-D WM 84/ EM 93 (1pair)</p> <p>4LB</p>
<p>Code: ITSP 192-E WM 104/ EM 115 (1pair)</p> <p>5LB</p>	<p>Code: ITSP 192-F WM 128/ EM 138 (1pair)</p> <p>6LB</p>	<p>Code: ITSP 192-G WM 146/ EM 160 (1pair)</p> <p>7LB</p>	
<p>Code: ITSP 192-H WM 166/ EM 183 (1pair)</p> <p>8LB</p>	<p>Code: ITSP 192-J WM 188/ EM 207 (1pair)</p> <p>9LB</p>	<p>Code: ITSP 192-K WM 208/ EM 229 (1pair)</p> <p>10LB</p>	
<p>Code: ITSP 192-L WM 230/ EM 253 (1pair)</p> <p>11LB</p>	<p>Code: ITSP 192-M WM 250/ EM 275 (1pair)</p> <p>12LB</p>	<p>Code: ITSP 192-N WM 290/ EM 320 (1pair)</p> <p>15LB</p>	

FIXED-WEIGHT DUMBBELLS (KG)

- 1 set include 1 pair fixed weight dumbbells.
- Thick, durable vinyl/neoprene coats.
- Colorful, no rust and smooth surface.

NOTE: **COLORS ARE RANDOM**



Vinyl/
Neoprene
Coated

Code: ITSS-043-A
WM 42/ EM 46 (1pair)

1KG

Code: ITSS-043-B
WM 62/ EM 68 (1pair)

1.5KG

Code: ITSS-043-C
WM 84/ EM 93 (1pair)

2KG

Code: ITSS-043-D
WM 104/ EM 115 (1pair)

2.5KG

Code: ITSS-043-E
WM 128/ EM 138 (1pair)

3KG

Code: ITSS-043-F
WM 188/ EM 207 (1pair)

4KG

Code: ITSS-043-G
WM 208/ EM 229 (1pair)

5KG

Code: ITSS-043-H
WM 250/ EM 275 (1pair)

6KG

Code: ITSS-043-J
WM 280/ EM 310 (1pair)

7KG

Barbell and Weights (Iron Cast) (1 Set) (139kg)

Code : ITSS - 002/ WM 2400/ EM 2640

Set includes: - 1x Steel Bar - 2x Barbell clip - 14x various weight plates

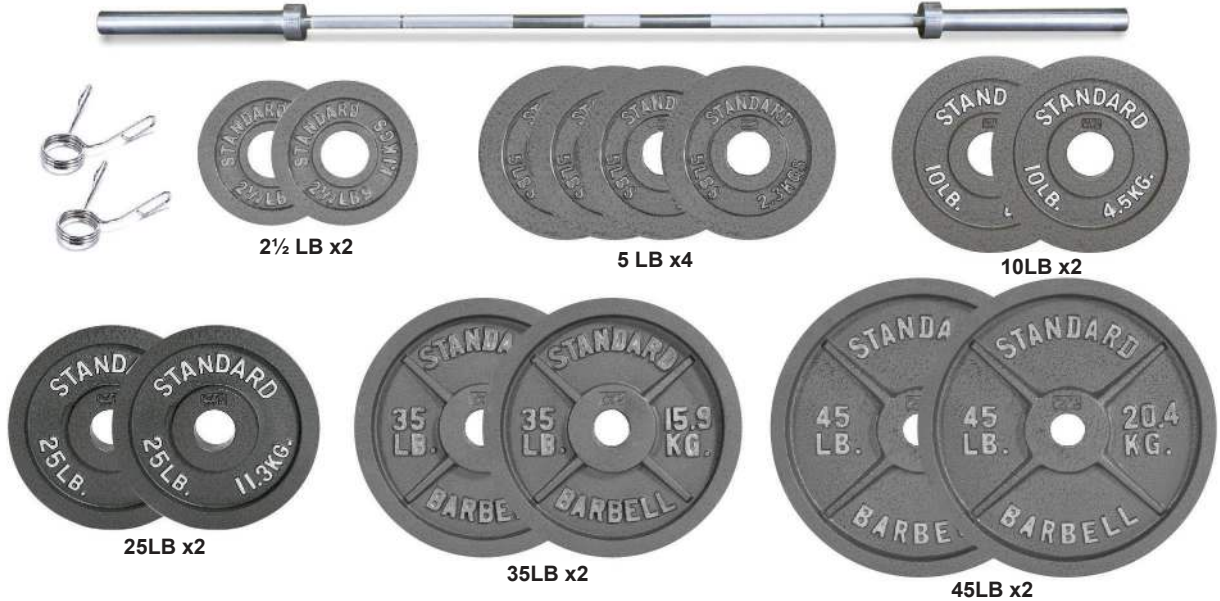

Barbell and Weights (Rubber Coated) (1 Set) (166kg)

Code : ITSS - 044/ WM 2900/ EM 3190

Set includes: - 1x Steel Bar - 2x Barbell clip - 12x various weight plates



20kg Chrome Dumbbell Set (23kg)

Code : ITSP - 134/ WM 460/ EM 490



Berkualiti



Nat : 4 Keping

Gagang Pemegang : 2 Batang

Berat Piring : 0.5kg x 4 Keping

Berat Piring : 1.25kg x 4 Keping

Berat Piring : 2.5kg x 4 Keping

Saiz Kotak : (P)24 x (L)16 x (T)42cm
Untuk Fitness Pembentukan Otot

Battle Rope (6kg)

Code : ITSP - 176/ WM 350/ EM 385



ALTERNATING ARM WAVES



FIGURE 8 CIRCLES



**KONSEP
KECERGASAN
DAN
KESIHATAN**

Material : Poly Dacron
Diameter : 30mm
Length : 12meter
Weight : 6kg
Colour : Black with
orange stripe

* Features :

- Build Stamina
- Burn Fat
- Gain Lean Muscle Mass
- Heat Shrink Caps on the ends
- High Tensile Strength
- Improve Cardiovascular Health
- Increase VO2 Levels
- Strengthen Core Muscles

Rope Pattern



CLAPPING

**PENDIDIKAN
JASMANI**

**AKTIVITI
FIZIKAL**

Push Up Pro (4 pair) (3.8kg)
Code : ITSP - 006/ WM 250/ EM 270



Sit Up Bench (8.2kg)
Code : ITSP - 007/ WM 450/ EM 490



- equipment
- exercise and fitness equipment
- bodybuilding equipment
- house-fitness equipment
- N.W : 7 kgs
- G.W : 8.2 kgs
- Size : (W)119 x (D)14 x (H)33 cm

EVA Jumping Hoop (0.5kg)
Code : ITSP - 041/ WM 175/ EM 190

- Safe N' Soft With rubber foam
- Great exercising tools for kids
- Improve children's balancing skill
- Have fun for whole family
- Indoor & outdoor
- Two feet stand on rubber pad, hold on grip handle tightly while jumping also for relay racing.

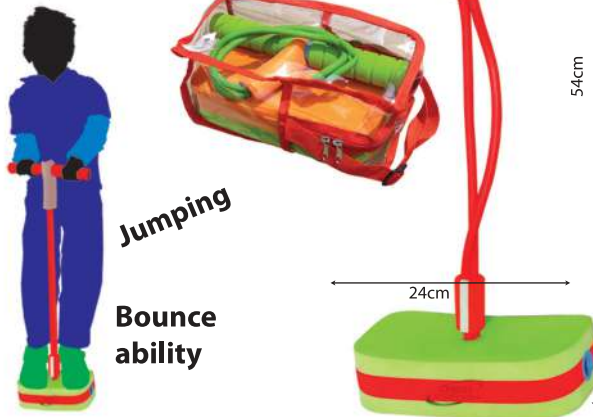

EVA Active Workout Kit (0.5kg)
Code : ITSP - 055/ WM 200/ EM 220 (Set of 4)

Lebih Ringan dan Mudah
Untuk Dikendalikan oleh
Kanak-Kanak.



Rubber Stretching Exercise (0.9kg)
Code : ITSP - 054/ WM 175/ EM 190 (Set of 10)



Basic Exercise Equipment (1.1kg)
Code : ITSP - 048/ WM 150/ EM 165

Set includes:

- Hand Grip x2
- Action Spring
- Jump Rope x1
- Rower x1



Climbing Rocks (5pcs) (0.8kg)
Code : ITSP - 082/ WM 130/ EM 140



Boxing Punch Bag (7.5kg)
Code : ITSP - 191/ WM 160/ EM 175

*Bag ONLY



Alatan Gimnastik Artistik (Set of 30pcs) (6.8kg)

Code : ITSP - 133/WM 895/ EM 985

BELANTAN 体操棒
Size : Ø4cm x 43cm
X 10pcs

GIMNASTIK REBEN 彩带
X 5pcs
- Panjang Reben : 600cm (6 meter)
- Diameter Reben : 5cm
- Pemegang besi : Ø1cm x 59cm

BOLA GIMRAMA 体操球
Size : Ø20cm
X 5pcs

REGANGAN GETAH 拉力带
X 5pcs
Size : (T)0.5cm x (L)3.5cm x (P)253cm

TALI 体操绳
Size : Ø1cm x 290cm
X 5pcs



Reben Gimnastik (0.1kg) Code : ITSP - 153/WM 28/ EM 30 (1pc)

6 Meter



Kandungan :

- Set dilengkapi dengan multi warna reben.
- Setiap reben mempunyai pemegang besi.
- Reben : Diperbuat dari bahan fabrik berkualiti.
- Panjang Reben : 600cm (anggaran) 6 meter
- Diameter Reben : 5cm (anggaran)
- Pemegang besi : Ø1cm x 59cm

Set Reben ini amat sesuai untuk latihan gimnastik irama, latihan semasa pelajaran jasmani dan kesihatan (PJK), latihan berkumpulan juga merupakan aktiviti yang ideal.



Berkualiti

Regangan Getah (0.4kg)

Code : ITSP - 152/ WM 39/ EM 42 (1pc)

2.5meter



Berkualiti

Kandungan :

Bahan : Getah yang berkualiti, tahan lasak.

Warna : Merah dan hijau.

Size : (T)0.5cm x (L)3.5cm x (P)253cm

Alatan ini amat sesuai untuk latihan gimnastik irama, latihan semasa pelajaran jasmani dan kesihatan (PJK), latihan berkumpulan juga merupakan aktiviti yang ideal.

Objektif Pengajaran dan Pembelajaran :

Meningkatkan keyakinan diri dalam melakukan sesuatu aktiviti, disamping memupuk kerjasama dan semangat berkumpulan semasa latihan dan aktiviti serta disiplin.



Belantan Gimnastik Berirama (0.4kg)

Code : ITSP - 154/ WM 45/ EM 49 (1pc)

KONSEP
KECERGASAN
DAN
KESIHATAN



Kandungan :

Bahan : Plastik yang berkualiti, tahan lasak.

Warna : Merah, jingga, biru, hijau dan ungu.

Size : Ø4cm x 43cm

Set ini amat sesuai untuk latihan gimnastik irama, latihan semasa pelajaran jasmani dan kesihatan (PJK), latihan berkumpulan juga merupakan aktiviti yang ideal.

Objektif Pengajaran dan Pembelajaran :

Meningkatkan keyakinan diri dalam melakukan sesuatu aktiviti, disamping memupuk kerjasama dan semangat berkumpulan semasa latihan dan aktiviti serta disiplin.

AKTIVITI
FIZIKAL

Bola Gimrama (0.4kg)

Code : ITSP - 155/ WM 60/ EM 66 (1pc)



Ø20cm

Kandungan :

Bahan : Getah yang lembut

Warna : Merah, jingga, biru, hijau dan ungu.

Size : Ø20cm

Bola gimrama ini amat sesuai untuk latihan gimnastik irama, latihan semasa pelajaran jasmani dan kesihatan (PJK), latihan berkumpulan juga merupakan aktiviti yang ideal.

Objektif Pengajaran dan Pembelajaran : Meningkatkan keyakinan diri dalam melakukan sesuatu aktiviti, disamping memupuk kerjasama dan semangat berkumpulan semasa latihan dan aktiviti serta disiplin.



Tali Gimnastik Berirama (0.1kg)

Code : ITSP - 156/ WM 28/ EM 30 (1pcs)

Kandungan :

Bahan : Tali yang berkualiti, tahan lasak.

Warna : Merah, jingga, biru, hijau dan ungu.

Size : Ø1cm x 300cm

Tali ini amat sesuai untuk latihan gimnastik irama, latihan semasa pelajaran jasmani dan kesihatan (PJK), latihan berkumpulan juga merupakan aktiviti yang ideal.

Objektif Pengajaran dan Pembelajaran : Meningkatkan keyakinan diri dalam melakukan sesuatu aktiviti, disamping memupuk kerjasama dan semangat berkumpulan semasa latihan dan aktiviti serta disiplin.



3 Meter

Size : Ø1cm x 290cm



Gimnastik Berirama (Riben) (Set of 50) (0.4kg)

Code : ITSP - 113/ WM 130/ EM 143



Panjang Riben: 180cm
Pemegang Plastik: 39cm

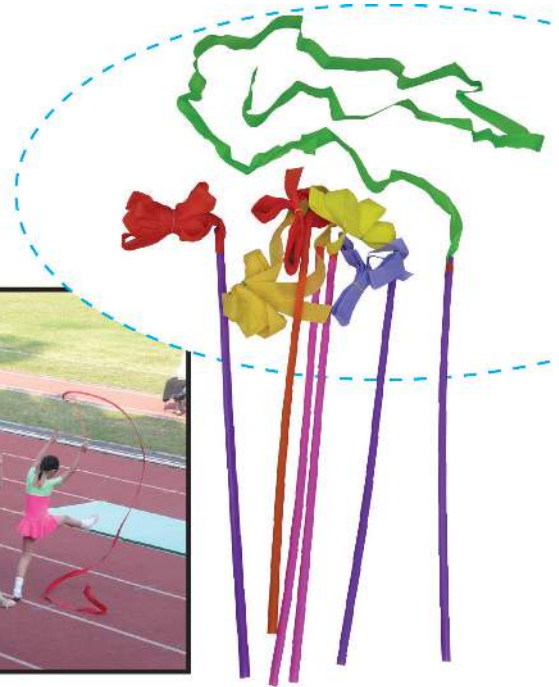

Palang Sejajar (Fleksibel) (1 Unit) (44.4kg)

Code : ITSP - 165/ WM 1850/ EM 2000



Selepas pusing skru, kemudian tarik ke belakang dan tarik bahagian besi ke atas untuk ketinggian yang dikehendaki.

Konsep Kecergasan Dan Kesihatan



Mengikut Silibus Pendidikan Jasmani Teknologi Tahun 6
单元一“趣味体操乐无穷”
六年级，第五页及第六页

Senam Palang Sejajar (Dipasang Kekal) (1 Unit) (9.9kg)

Code : ITSP - 166/ WM 1180/ EM 1290

Konsep Kecergasan Dan Kesihatan

Kemahiran Motor Kasar

PENDIDIKAN JASMANI

Berkualiti



Mengikut Silabus Pendidikan Jasmani Teknologi Tahun 6
单元一“趣味体操乐无穷”
六年级，第五页及第六页



Boleh Laras seperti gambarajah

D.I.Y

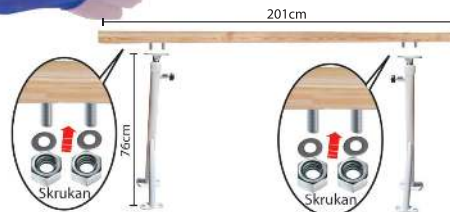

Selepas pusing skru, kemudian tarik ke belakang dan tarik bahagian besi ke atas untuk ketinggian yang dikehendaki.



Dinding Palang Bar (1 Unit) (11.8kg)

Code : ITSP - 168/ WM 1500/ EM 1650

Pendidikan Jasmani

Berkualiti



Konsep Kecergasan Dan Kesihatan



Mengikut Silabus Pendidikan Jasmani Teknologi Tahun 6
单元一“趣味体操乐无穷”
六年级，第五页及第六页

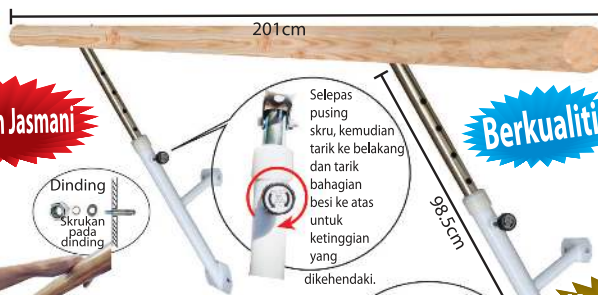

Selepas pusing skru, kemudian tarik ke belakang dan tarik bahagian besi ke atas untuk ketinggian yang dikehendaki.



Kemahiran Motor Kasar



Boleh Laras seperti gambarajah



Aktiviti Fizikal

Bangku Gimnastik (7.6kg)
Code : ITSP - 164/ WM 455/ EM 480

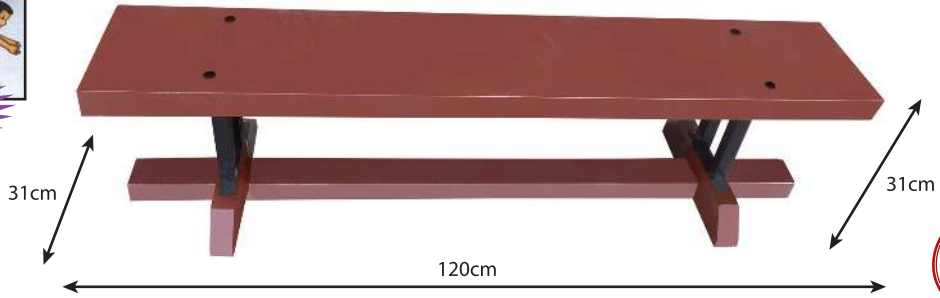

Berkualiti

Bangku Gimnastik (14.8kg)
Code : ITSP - 151/ WM 695/ EM 750

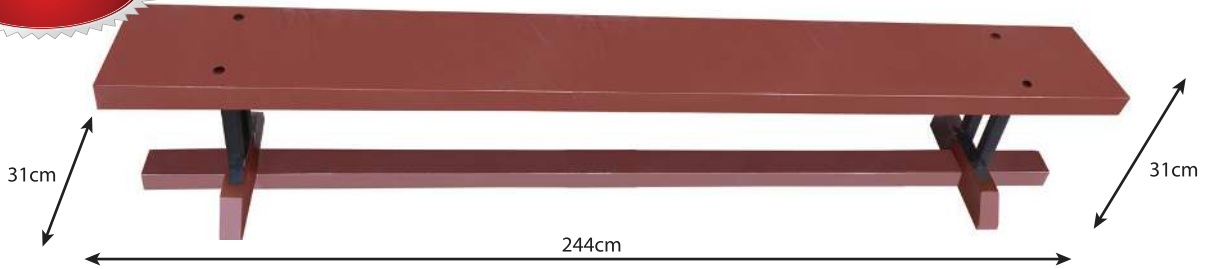

Konsep Kecergasan Dan Kesihatan

Kemahiran Motor Kasar

Mengikut Silibus Pendidikan Jasmani Dan Pendidikan Kesihatan Tahun 1,4.
Unit 1, Bertajuk Gimnas Jaya.
该产品被列为教科书，一年级及四年级体育与健康教育。

Tahun 1 (m/s 26)



Tahun 1 (m/s 43)

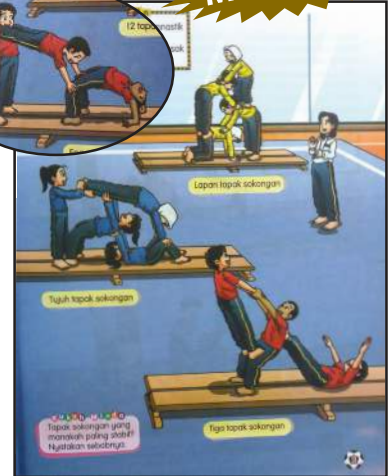

Tahun 4 (m/s 02)

PENDIDIKAN JASMANI

Palang Ayun

Code : ITSP - 123/ WM 3300/ EM 3600

- Diperbuat dari bahan besi yang berkualiti dan bertahan lasak.
- Diwarnakan dengan bahan pewarna yang tahan luntur.
- Set tiga barsilang yang mampu untuk menampung tiga orang.
- Melatih otot-otot lengan
- Pertumbuhan dan perkembangan fizikal.

Genggaman bawah digunakan untuk berayun ke belakang.

Genggaman atas digunakan untuk berayun ke hadapan.

Genggaman campur digunakan untuk bertukar posisi.



AKSI BERGAYUT DAN BERAYUN

Konsep Kecergasan Dan Kesihatan

Bergayut ialah bergantung pada palang dengan menggenggam palang secara genggaman atas, genggaman bawah dan genggaman campur sambil mengayuhkan badan. Jenis genggaman perlu sesuai dengan arah ayunan yang dilakukan.



Kemahiran Motor Kasar

Berkualiti

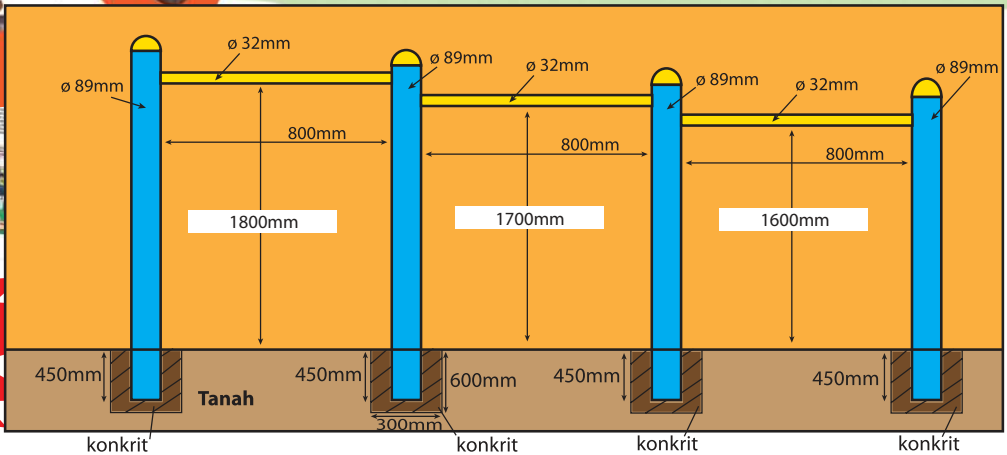

Mengikut Silibus Pendidikan Jasmani Teknologi Tahun 1,2,4 Unit 1 "GIMNAS JAYA" yang Bertajuk Palang Ayun

Taiji Rouli Ball Racket (Set Of 6) (2.5kg)

Code : ITSP - 126/ WM 320/ EM 350

太极柔力球是一种体育健身用具,它是在球拍框内安装了一张由橡胶、塑料或橡塑合成柔软有弹性的材料制作的拍面,并在拍面上设置了防滑凸凹点和增加柔软度的通孔。

材质 : 铝合金



塑料球



帆布背包

球拍

球拍 : (H) 47cm x (W) 22cm
塑料球 : Ø7cm

Sports Stacking Cup Full Set (With Timer)

Code : ITSP - 190/ WM 190/ EM 210 (1kg)

Set mengandungi: 1 keping mat (tikar), 1 timer sentuh, 12 stacking cup

Dengan kotak simpanan



2 AAA bateri
(TIDAK DISEDIAKAN)



Kemahiran Motor Kasar

Beyond A Tennis Ball (8 pair) (3kg)
Code : ITSP - 001/ WM 340/ EM 370



Lighted Wheel Exercise (Set of 10)
Code : ITSP - 010/ WM 200/ EM 220 (2.2kg)



On Target C/W 3 Balls (1 Set) (0.9kg)
Code : ITSP - 024/ WM 195/ EM 215

1 set include 3 balls and
1 pcs bag target with velcro.



Foot Balancing Games (Set of 32pcs)
Code : ITSP - 040/ WM 385/ EM 420 (3.2kg)



These plastic buckets are made by using very high and fine quality plastic raw material which ensures high durability at its user end and helps prevent stress cracks.



Throw The Ring With Elephant

Code : ITSP - 013/ WM 385/ EM 420 (5.3kg)



Master Balancing Egg (1 Units) (1.7kg)

Code : ITSP - 026/ WM195/ EM 215



Swinging Loop (Set of 4) (1.1kg)

Code : ITSP - 117/ WM 220/ EM 240



Educational Traffic Light (1 Unit)

Code : ITSP - 019/ WM 940/ EM 990 (3.5kg)



Traffic Sign Boards (12 Types) (6kg)

Code : IT - 034/ WM 750/ EM 820

(Pendidikan Keselamatan Jalan Raya)

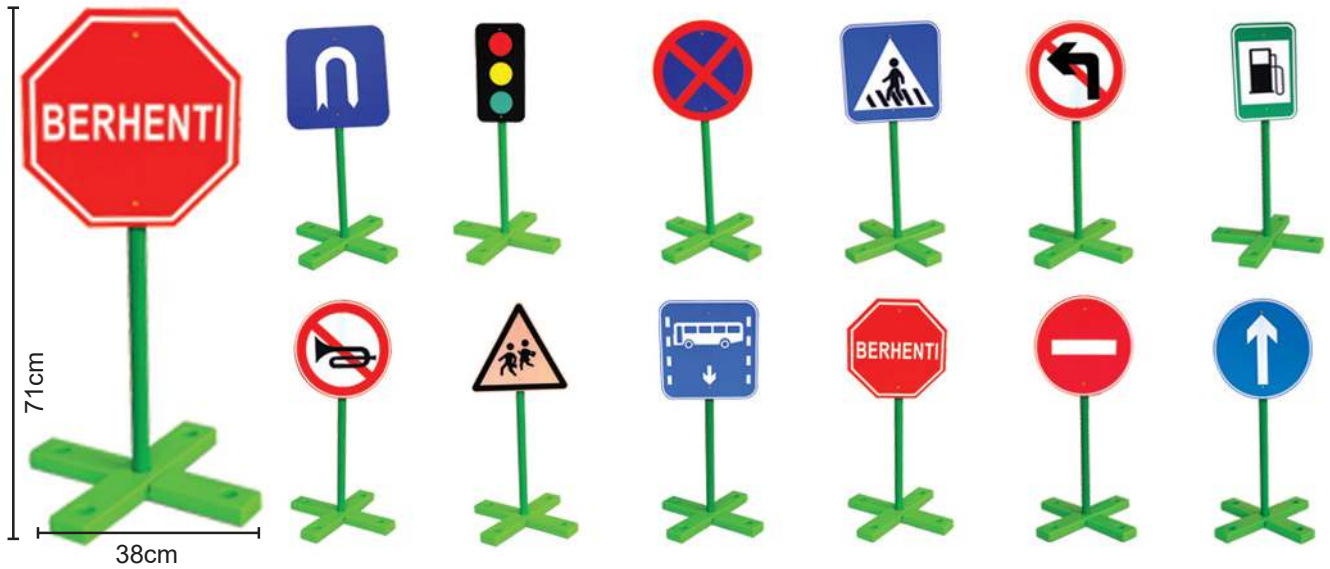

Kids Bicycle 9213 (5.3kg)

Code : IXT - 081/ WM 900/ EM 990 (1 Unit)



Tricycle Scuttle Bug (1 Unit) (2.3kg)

Code : ITSP - 017/ WM 170/ EM 190



Educational Junior Tricycle (1 Unit)

Code : ITSP - 018/ WM 435/ EM 470 (72kg)



ABC La Cosa (1 unit) (3.1kg)

Code : ITSP - 119/ WM 495/ EM 540



Handy Trolley Carts (1 Unit) (18kg)

Code : IT - 028/ WM 650/ EM 700



Pedal Roller (1 Unit) (2.6kg)
Code : IXT - 035E/ WM 200/ EM 220



Twin Walker (1 Unit) (9kg)
Code : IXT - 035G/ WM 325/ EM 350



Walking See-Saw (0.7kg)
Code : IXT - 035L/ WM 130/ EM 145

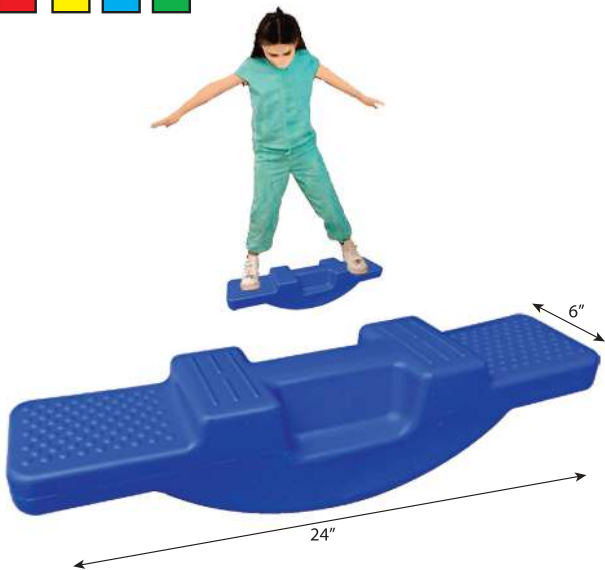
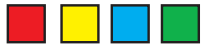

Rocking See-Saw (1.3kg)
Code : IXT - 034D/ WM 150/ EM 165



Aktiviti integrasi sensori ialah sesuatu permainan yang dapat merangsangkan deria penyentuhan, perimbangan, otot, sendi, kulit dan penglihat, pendengaran, penghiduan kanak-kanak serta berintergrasi dengan pergerakan kanak-kanak. ini dapat mempercepatkan proses penyesuaian dan berdikari kanak-kanak



S Balance Beam (2 Unit) (10.6kg)
Code : IXT - 031-6/ WM 1600/ EM 1760



183 x 15cm (6 feet)

Giant Spinning Top (6.5kg)
Code : IXT - 033G/ WM 780/ EM 850



Balancing Turtle (1 Unit) (2.9kg)
Code : IXT - 035A/ WM 200/ EM 220



Flexible Motor Skills Set
Code : IXT - 037E/ WM 5200/ EM 5700
(Set of 3)

Size : 220 x 105cm



River Stone (Set of 11 pcs) (5.8kg)
Code : IXT - 035N/ WM 860/ EM 950



Hemisphere (Set of 20 pcs) (3.3kg)
Code : IXT - 035M/ WM 480 / EM 520



Size: ϕ 15.5cm

Balance Board Walk (20 pcs) (8.7kg)
Code : IXT - 039B/ WM 980/ EM1080

Descriptions:
Rectangular tactile paths that can be arranged into different routes. The unique protruding dots on the paths stimulate users' foot soles and enhance their balance and coordination.



Square blocks can be combined with the paths to have four different directions.



Tactile path can be arranged in different variations.



Size : 49 x 13.5 x 7cm
Curve x 8 pcs
Straight x 8 pcs
Square x 4 pcs



This curve walking path set can be arranged into many different patterns and stimulate the feet while providing a balancing grip.

Motor Skill Activity Set (Full Set) (18.4kg)

Code : IXT - 040A/ WM 1550/ EM 1700

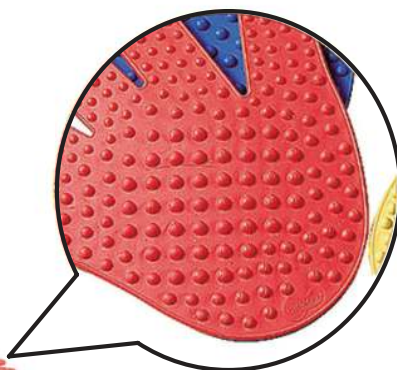

Components include:

- Half Brick
- Brick
- Balance Beam
- Pole 35cm
- Pole 70cm
- Hoop 35cm
- Hoop 60cm
- Clip Hoop/poles
- Clip poles
- Bean Bag
- Footprint
- Handprint

- 12 pcs
- 8 pcs
- 4 pcs
- 16 pcs
- 8 pcs
- 4 pcs
- 4 pcs
- 12 pcs
- 12 pcs
- 10 pcs
- 6 pcs
- 6 pcs



Rainbow Parachute (3.6M) (1kg)

Code : ITSP - 030/ WM 250/ EM 275

Suitable to play in group where it encourage cooperative play. Made with light-weighted nylon. Size: 3.6 metre (diameter)



Partner Parachute Kit (0.6kg)

Code : ITSP - 031/ WM 200/ EM 220

Saiz parachute:

88 cm x 127 cm

Set termasuk:

- Pundi kacang 4pcs
- Parachute 1pcs
- Beg 1pcs



i-Running Parachute i-训练伞 (0.4kg)

Code : ITSP - 059/ WM 140/ EM 155 (per pcs)



Beg tali jerut disediakan supaya mudah disimpan dan dibawa.

- Digunakan untuk latihan larian.
- Meningkatkan kemampuan pelari.
- Parachute diikat pada pinggang dan larian dibuat sehingga parachute mengembang.

Permainan Ting-Ting (1.3kg) Code : ITSP - 111/WM 160/ EM 175

Mengandungi :
1 Playmat Plastik
4 biji Pundi Kacang
5 biji butang
(Merah,Kuning,Hijau Dan Biru)

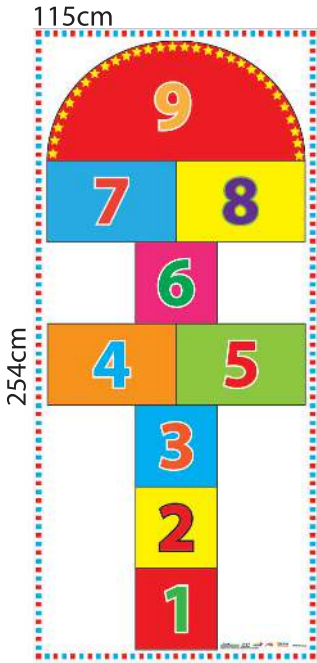

Mengikut Subjek Pendidikan Jasmani dan Pendidikan Kesihatan Tahun 3
该产品被列为教科书三年级体育与健康教育里的单元九“跳飞机”



Jump & Leap Activity (2kg) Code : ITSP - 189/WM 145/ EM 160

- Size: 2.5 feet (W) x 15 feet (H)
- Material: Tarpaulin (Banner)
- Improves gross motor skills
- Encourages physical activity
- Develops jumping techniques
- Enhances social interaction
- Supports cognitive skills
- Great for all ages
- Perfect for indoor & outdoor play

Kemahiran Motor Kasar

Pendidikan Jasmani

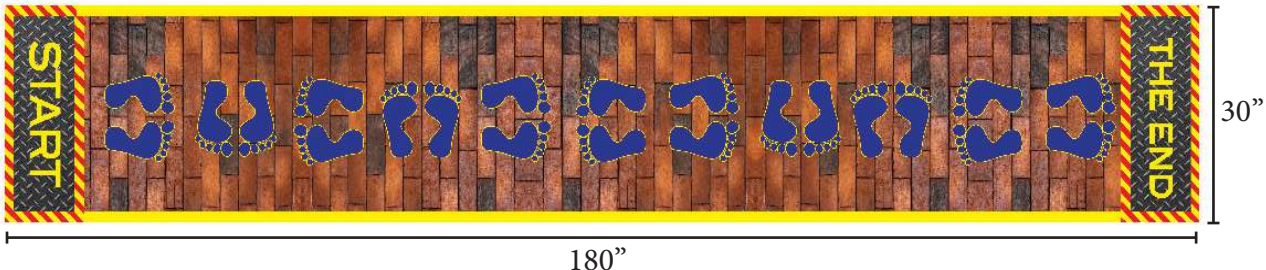

Poster Atlet Kebangsaan (Set of 10)

Code: ITC-048/ WM 250/ EM 275



Poster Info Asas Sukan (Set of 8)

Code: ITC-049/ WM 200/ EM 220

- Set ini mengandungi 8 keping poster berkaitan sukan.
- Poster ini menunjukkan info asas setiap permainan sukan.
- Sesuai di tampilkan di papan info sekolah.
- Material: 5mm KT Foam Board dan whitesticker.
- Saiz: 29.7cm x 42cm



MUDAH PASAN
BOLEH TAMPAL
INDOOR & OUTDOOR
BERKUALITI

Carta Panduan Penggunaan Alatan Segak (5's) **BM or BC** (1.9kg)

Code : Segak - 005/WM 390/ EM 430

Size : 2 x 5 feet

DAYA TAHAN KARDIOVASKULAR

NAIK TURUN BANGKU YMCA
Menentukan tahap keupayaan kardiovaskular



PROSEDUR

1. Gunakan kotak atau bangku 12 inci tinggi.
2. Metronome diletakkan pada 96 detik seminit.
3. Benderi legak dengan kedua-dua tangan di atas.
4. Pandang ke hadapan.
5. Mula
 - Naik dan turun bangku dengan menggunakan sebelah kaki dikukus dengan sebelah kaki lagi mengikut detik metronome.
 - Ulang selama 3 minit.
6. Selepas 3 minit duduk dan ambil bacaan nadi serta merta.
7. Rekod bacaan nadi bagi 1 minit penuh.

NO:1

FLEKSIBILITI

JANGKAUAN MELUNJUR
Melunjur tahap kelenturan otot di bahagian paha dan punggung

PROSEDUR

POSISI MULA

1. Duduk melunjur dan rapatkan kaki.
2. Tangan kanan diletakkan di atas tangan kiri.
3. Ekstensi lutut sepenuhnya.



SEMASA MENJANGKAU

1. Ekstensi lengan sepenuhnya.
2. Rapatkan dagu ke dada dan tolak penanda sejauh yang boleh tanpa henjutan.



3. Tahan sehingga 3 saat pada jangkauan maksimum.
4. Lakukan 3 kali ujian.
5. Catatkan ukuran yang paling jeuh.

NO:2

DAYA TAHAN KEKUATAN OTOT

RINGKUK TUBI
Menentukan daya tahan dan kekuatan otot tot abdomen.



1. Baring dan fleksikan lutut 90° serta jarakkan 12 inci antara kaki dan punggung.
2. Rehatkan kepala.
3. Lengan di sisi mencecah garisan 1.
4. Pastikan tumit sentiasa mencecah lantai.
5. Tetapkan metronome pada 50 detik seminit.
6. Ratakan badan.
7. Semasa bangun
 - bangun pada setiap detik metronome dan turun pada detik seterusnya.
 - Jangan mencecah garisan B. 10 sentimeter dari garisan A.
 - Ulang mengikut detik metronome.
8. Berhenti jika
 - Cukup 1 minit
 - Berhenti jika terasa sakit dan kurang selesa.
 - Jika tidak dapat melakukan teknik ringkuk yang sama.



NO:3

DAYA TAHAN KEKUATAN OTOT

TEKAN TUBI
Menilai daya tahan dan kekuatan otot tot di bahagian anggota atas badan



PROSEDUR

1. Posisi mula dalam keadaan sokong ke hadapan.
2. Tangan lurus dengan kestabilan kepala tangan di lantai.
3. Bukakan lengan sejauh bahu.
4. Badan dan kaki lurus dengan hujung kaki mencecah lantai.



WANITA MELUTUT DAN KAKI DISILANGKAN

5. Pandang kebawah.
6. Fleksi siku sehingga dada berada 10 sentimeter dari lantai.
7. Ulang aktiviti sehingga berhenti.
8. Rekodkan jumlah fleksi.

Peringatan

- Berhenti jika terasa sakit dan kurang selesa atau tidak dapat melakukan teknik bangun yang sama.
- Rehat pada kedudukan posisi mula.



NO:4

KOMPOSISI BADAN

INDEKS JISIM BADAN (BMI Body Mass Index)
Indek jisim badan adalah satu teknik pengukuran menggunakan nisbah berat badan



Formula ukuran UB = $\frac{\text{Berat (kg)}}{\text{Tinggi(m)}^2}$

PERINGATAN

1. Letakkan alat penimbang di tempat rata dan tanpa berlapis
2. Pakai pakaian nipis dan tanpa berkasut
3. Berdiri legak di atas alat penimbang
4. Pandang ke hadapan
5. Catat

PROSEDUR

1. Ketinggian diukur tanpa memakai kasut
2. Berdiri legak tangan lurus di sisi badan
3. Tumit kaki kepala belakang bahu dan pinggul menyentuh rod pengukuran
4. Pandang ke hadapan
5. Tarik dan tahan pernafasan
6. Turunkan pelaras ukuran ketinggian sehingga menyentuh kepala
7. Rekodkan bacaan dalam ukuran meter(m)

NO:5

Digital Health Scale (12.6kg) Code : IT - 001/WM 940/ EM 990



Mechanical Health Scale (4.2kg) Code : IT- 002/ WM 600/ EM 660



Bangku Naik Turun (10.2kg)
Code : Segak - 001/ WM 395/ EM 430



Alat Pengukur Jangkauan Melunjur
Code : Segak - 002/ WM 365/ EM 400 (5.8kg)



Bangku Naik Turun (Ada Mat) (10.3kg)
Code : Segak - 003/ WM 435/ EM 470



L-Plastic Jangkauan Melunjur (0.5kg)
Code : Segak - ACC/ WM 16/ EM 17



Digital Stop Watch (0.2kg)
Code : ITSP - 003/ WM 49/ EM 54

Size : (W)6.5cm x (H)8cm



Heart Rate Monitor Stop Watch c/w
Code : Segak - 004/ WM 235/ EM 250 (0.1kg)



Exercise Mat with Bag (1kg)
Code : IT - 032/ WM 80/ EM 88



Exercise Mat (0.9kg)
Code : ITSP - 002/ WM 69/ EM 76



Size: 68" x 28" x 6mm (thickness)



Beg Alat Pengukur Jangkauan (0.3kg)
Code : Segak - 006/ WM 45/ EM 49 (1pcs)



Beg Bangku Naik Turun (0.3kg)
Code : Segak - 007/ WM 59/ EM 65 (1pcs)



Metronome (0.6kg)
Code : ITMZ - 003/ WM 235/ EM 255

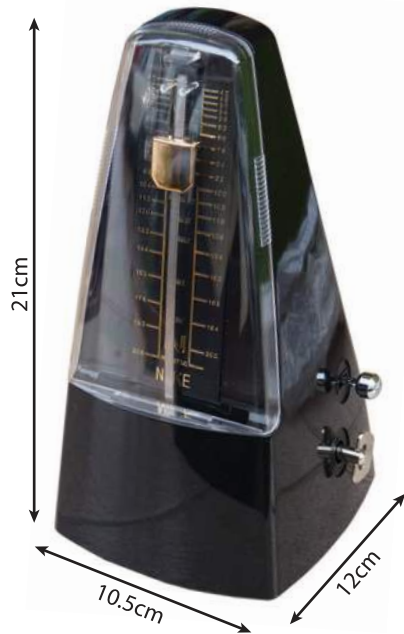

Digital Charging Metronome (0.3kg)
Code : ITMZ - 055/ WM 159/ EM 175



MINDA SIHAT BIMBINGAN DAN KAUNSELING

(SESUAI UNTUK SEKOLAH MENENGAH DAN SEKOLAH RENDAH) (2.4kg)



Code : ITMG - 008
WM 280/ EM 300

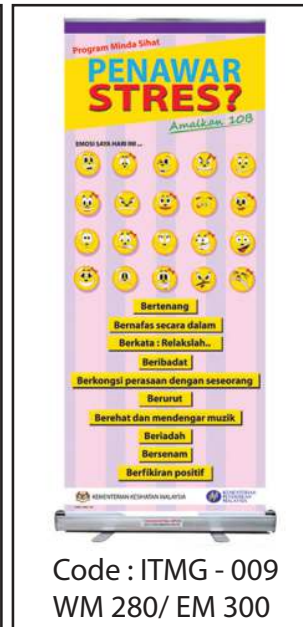

Code : ITMG - 009
WM 280/ EM 300



Code : ITMG - 010
WM 280/ EM 300



Code : ITMG - 011
WM 280/ EM 300



Code : ITMG - 012
WM 280/ EM 300

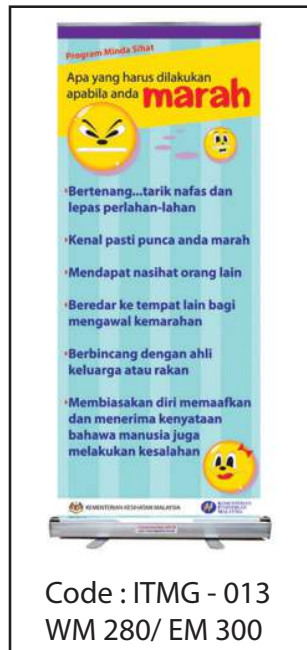

Code : ITMG - 013
WM 280/ EM 300



Code : ITMG - 014
WM 280/ EM 300

MINDA SIHAT POSTER (0.54kg)

BIMBINGAN DAN KAUNSELING

Adakah anda Stres?
Senyum Selalu
Uruskan stres anda
Anda pasti bahagia dan ceria

Code : ITMG - 018
WM 120/ EM 132

Saya Tugasi Stres Secara Positif
Jika fikiran saya positif
Saya Rasa Positif
Kehidupan KITA jadi Positif
Tindakan Saya Juga positif

Code : ITMG - 019
WM 120/ EM 132

10 Langkah ke arah kehidupan mental yang positif!

1. Menerima kenyataan diri secara realistik.
2. Mengendali masa dengan baik (time management).
3. Menawang perubahan dalam kehidupan secara bijak.
4. Mempunyai hubungan harmoni dan kasih sayang dengan ahli keluarga dan orang lain.
5. Menjaga kebersihan diri.
6. Menyediakan masa untuk aktiviti rehat dan riadah.
7. Memastikan rehat dan tidur yang cukup.
8. Mengendalikan stres secara berkesan.
9. Mengendalikan nilai-nilai moral.
10. Berkomuni masalah dengan orang lain dan mendapat pertolongan profesional sekiranya perlu.

Code : ITMG - 020
WM 120/ EM 132

Program Minda Sihat
EMOSI SAYA HARI INI ...

Boleh digantung

42cm x 59cm x 2.5cm

Akibat kesihatan mental yang diabaikan seseorang itu mungkin mengalami...

- Perasaan rendah diri,
- Tekanan dalam hidup,
- Persekitaran dan keruntuhan rumah tangga / keluarga,
- Kecenderungan melakukan kegiatan tidak beroriental (penyalahgunaan dadah, minum arak dan/atau substance mahram),
- Kecenderungan melakukan kegiatan untuk menyelesaikan masalah (penderaan kanak-kanak, pasangan, buli jalaranya, buli sekolah),
- Peningkatan risiko penyakit mental.

Code : ITMG - 021
WM 120/ EM 132

Penawar Stres? Amalkan 10B

- Bertenang
- Bernafas dengan dalam
- Berkata: relaksah...
- Beribadat
- Bercakap dengan seseorang
- Berurut
- Berehat dan mendengar muzik
- Beriadah
- Bersenam
- Berfikirkan positif

Code : ITMG - 022
WM 120/ EM 132

Kenapa Seseorang Memendam Perasaan?

- Malu
- Takut menjadi bebanan kepada orang lain
- Terlalu peribadi untuk dibincang
- Berpendapat diri sudah matang dan tahu bagaimana untuk mengatasinya
- Bingung akan reaksi orang lain
- Berpendapat tiada siapa mahu mendengar dan memahami
- Takut dianggap lemah jika tidak dapat menyelesaikan masalah sendiri
- Berfikir-lanya hanya perkara kecil

Code : ITMG - 023
WM 120/ EM 132

Bagaimana Mengendalikan Perasaan Anda

- Ketahui perasaan anda
- Luahkan perasaan anda
- Dengar pendapat orang lain tentang perasaan anda
- Kongsi perasaan anda dengan pasangan hidup, ahli keluarga, rakan, jiran, pemimpin agama, doktor, kaunselor dan anggota kesihatan

Code : ITMG - 024
WM 120/ EM 132

Kebahagiaan yang Diperolehi Apabila Anda Berkongsi Perasaan

- Anda merasa lega
- Mengurangkan stres anda
- Anda akan menyedari orang lain juga mempunyai masalah
- Anda mungkin dapat mencari penyelesaian kepada permasalahan
- Masih ada orang yang mengasihani dan mengambil berat terhadap diri anda

Code : ITMG - 025
WM 120/ EM 132

Kenapa anda Stres

- Gagal dalam ujian / peperiksaan
- Tidak diterima oleh rakan
- Dimarahi guru
- Gagal menyiapkan kerja sekolah
- Kematian ahli keluarga
- Harapan keluarga yang terlalu tinggi
- Diri sendiri - kecewa
- Kesesakan lalu lintas
- Persekitaran yang tidak selesa
- Tragedi

Code : ITMG - 026
WM 120/ EM 132

Apa yang harus dilakukan apabila anda marah

- Bertenang...tarik nafas dan lepas perlahan-lahan
- Kenal pasti punca anda marah
- Mendapat nasihat orang lain
- Beredar ke tempat lain bagi mengawal kemarahan
- Berbicara dengan ahli keluarga atau rakan
- Membiasakan diri memaafkan dan menerima kenyataan bahawa manusia juga melakukan kesalahan

Code : ITMG - 027
WM 120/ EM 132

Tanda-tanda Stres

- Jantung berdebu kencang
- Cepat marah
- Rasa tidak gembira
- Hilang selera makan
- Hilang minat kerja
- Tidak cukup tidur
- Suka menengking
- Cuba jauhan diri

Code : ITMG - 028
WM 120/ EM 132

EMOSI SAYA HARI INI ...

Code : ITMG - 029
WM 120/ EM 132

Kesihatan mental dan anda

Kesihatan mental berkait rapat dengan kehidupan seharian kita. Orang ramai sering mengabaikan kesihatan mental dengan penyakit mental, tetapi ini adalah kurang tepat. Ia melibatkan kehidupan sehari yang menyenangkan. Menikmati perasaan, nikmat dan juga aktiviti yang positif dalam diri sendiri. Kesihatan mental berbeza-beda kerana ia berkait dengan orang lain, hubungan dan persekitaran. Bagaimana seterusnya yang menjadikan tanggungjawab, masalah dan tekanan yang dihadapi dan kehidupan harian.

Code : ITMG - 030
WM 120/ EM 132

Menara Impian (Kit Aktiviti Perkhemahan) (2.5kg)

Code : ITKK - 043/ WM 290/ EM 320

Pengenalan

Menara Impian ialah satu Alat Bantu Mengajar (ABM) yang boleh digunakan untuk kepelbagaian aktiviti di luar bilik darjah yang interaktif, efektif dan menyeronokkan.

Menara Impian ialah satu set modul aktiviti yang mempunyai batang kayu dan tali ikatan.



Kemahiran

- Kemahiran Komunikasi Berkesan
- Kemahiran Mendengar
- Kemahiran Mengikuti Arahan
- Kemahiran Kepimpinan
- Latihan Jati Diri
- Latihan Yakin Diri

- Tali**
- Warna Biru.....50cm x 20pcs
 - Warna Kuning.....50cm x 20pcs
 - Warna Hijau.....50cm x 20pcs
 - Warna Merah.....50cm x 20pcs
 - Warna Ungu.....50cm x 20pcs

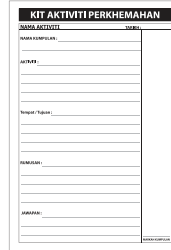

Kad Markah
x 10pcs



Buku Panduan x 2

- Batang Kayu**
- 1) 15cm x 100 batang
 - 2) 30cm x 50 batang



Render Matlamatku (Kit Aktiviti Perkhemahan) (1.5kg)

Code : ITKK - 044/ WM 390/ EM 420

Pengenalan

Render Matlamatku ialah satu Alat Bantu Mengajar (ABM) yang boleh digunakan untuk kepelbagaian aktiviti di luar bilik darjah yang interaktif, efektif dan menyeronokkan.

Render Matlamatku ialah satu set modul aktiviti yang mempunyai kain penutup mata, nota aktiviti dan tali aktiviti.



- Tali Sukan**
- 1 Gulung Tali..... 100 meter



- Kain Penutup Mata**
- Warna Biru.....8 helai
 - Warna Kuning..... 8 helai
 - Warna Perang..... 8 helai
 - Warna Hijau..... 8 helai
 - Warna Merah.....8 helai



Buku Panduan
x 2



Kad Markah
x 10pcs



(OUTDOOR / INDOOR)

Sports DVD (0.7kg)
Code : ITCD - 002/ WM 220/ EM 240 (5DVD)



运动 体育基础技术教程

Swimming DVD (0.5kg)
Code : ITCD - 003/ WM 175/ EM 192 (4DVD)



游泳

Power Hand (1.1kg)
Code : ITCD - 004/ WM 245/ EM 270
(4DVD) + (1Book)



Healthy Lifestyle (0.7kg)
Code : ITCD - 005/ WM 145/ EM 160
(2DVD) + (1 Book)



健康指南

Self Defense Skill (0.5kg)
Code : ITCD - 006/ WM 90/ EM 99
 (1DVD) + (1Book)

街头防身术



Taekwondo (0.4kg)
Code : ITCD - 007/ WM 90/ EM 99
 (1DVD) + (1Book)

跆拳道 实战技巧



Taekwondo (0.4kg)
Code : ITCD - 008/ WM 90/ EM 99
 (1DVD) + (1Book)



跆拳道 基础入门

Taekwondo Self-Defence (0.4kg)
Code : ITCD - 009/ WM 90/ EM 99
 (1DVD) + (1Book)



跆拳道 自卫防身术

Judo (0.4kg)
Code : ITCD - 010/ WM 90/ EM 99
 (1DVD) + (1Book)

柔道の技



Chinese National Taichi Competition 24 (0.4kg)
Code : ITCD - 011/ WM 90/ EM 99
 (1DVD)+(1Book)

中华 太极拳



Chen's Taichi Fundamentals 22 (0.4kg)
Code : ITCD - 012/ WM 90/ EM 99
 (1DVD) + (1Book)

陈式
 太极基础22式



Karate (0.4kg)
Code : ITCD - 013/ WM 90/ EM 99
 (1DVD) + (1Book)

武道馆 空手道



Pendidikan Kesihatan (0.5kg)
Code : ITCD - 014/ WM 90/ EM 99
(1DVD) + (1Book)



Nutrition & Healthy Eating (0.4kg)
Code : ITCD - 015/ WM 90/ EM 99
(1DVD) + (1Book)

相宜相克



Eliminating Toxin From Your Body (0.5kg)
Code : ITCD - 016/ WM 90/ EM 99
(1DVD) + (1Book) (0.5kg)

**你我食毒无奈，
 人体解毒有方**



Family Medicine - Chest (0.4kg)
Code : ITCD - 017/ WM 90/ EM 99
(1DVD) + (1Book)

家庭小药箱



300 Kinds Of Food You Must Eat During Your Life (0.6kg)

Code : ITCD - 018/ WM 90/ EM 99
(1VCD) + (1Book)

你一生必吃的
300种食物



Ping - Pong (0.5kg)

Code : ITCD - 020/ WM 90/ EM 99
(1DVD)+(1Book)

乒乓球



Swimming (0.5kg)

Code : ITCD - 019/ WM 90/ EM 99
(1DVD) + (1Book)

游泳



Basic Badminton Class (0.5kg)

Code : ITCD - 021/ WM 90/ EM 99
(1DVD) + (1Book)

羽毛球

基础与实战技巧



Basketball (0.5kg)

Code : ITCD - 022/ WM 90/ EM 99
(1DVD) + (1Book)



篮球

Football (0.5kg)

Code : ITCD - 023/ WM 90/ EM 99
(1DVD) + (1Book)



足球

Tennis (0.4kg)

Code : ITCD - 024/ WM 90/ EM 99
(1DVD) + (1Book)

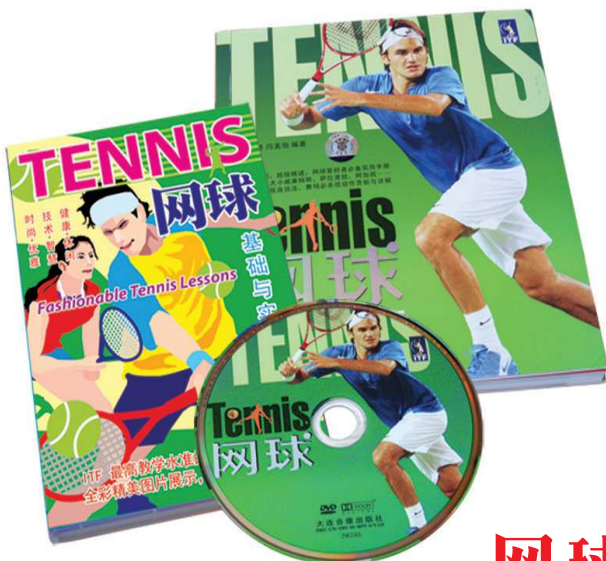

网球

Musical Instruments DVD Teaching Set (1.1kg)

Code : ITCD - 025/ WM 650/ EM 715



Versi BI

Versi BC

音乐教材